



PRATHIRAJ METAL MASTERS Pvt.Ltd.



Email : Jagadeesh@prathiraj.com.

Contact : K. Jagadeeswara Reddy, +91 9989826278.

INTRODUCTION



Activity :

- ✓ Designing & Manufacturing -- Injection Molds.
- ✓ Designing & Manufacturing -- Blow Molds.
- ✓ Drafting & Manufacturing -- Mold Bases for Injection molds.

Specialization :

- ✓ High Cavitation Injection Molds for Caps & Closures. (Specially for FMCG Products)
- ✓ Thin Wall Injection Molds.
- ✓ Blow Molds.
- ✓ High Cavitation Mold Bases for Caps & Closures .(Specially for FMCG Products)

Established :

- ✓ In the year 2004

INTRODUCTION



Promoters :

- ✓ Mr. M.Suresh Reddy.
- ✓ Mr. K.Srinivas.
- ✓ Mr. K.Jagadeeswara Reddy.
- ✓ Mr. C.Sridhar Reddy.

No of Molds Made Till Date :

- ✓ Blow Molds -- 175.
- ✓ Injection Molds -- 105.
- ✓ Mold Bases For Injection Molds – 1200.

Website :

- ✓ www.prathiraj.com – (Under Development)

INTRODUCTION



Prathiraj Metal Masters Pvt.Ltd



Amritha Tool Crafts Pvt Ltd – Unit-2
Support Activities :- Mold Trials and Validations



Parent Company :- Amritha Tool Crafts Pvt Ltd – Unit-1
Support Activities :- Wire Cut , Wire EDM , Laser Ablation

DESIGN CAPABILITY



✓ Software's	<ul style="list-style-type: none">✓ Creo 2.0 Parametric – 4 Sets.✓ Delcam (Power Mill & Power Shape) Version 11.0 – 2 Sets.✓ Feature Cam 2018 – 3 Sets.✓ Auto-cad LT 2018 – 5 Sets.
✓ Molds Designed	<ul style="list-style-type: none">✓ Hot Runner Molds.✓ Cold Runner Molds.✓ Thin Wall Molds.✓ Unscrewing Molds with Hydro motor, Rack.✓ Molds for Friction Fit Components.✓ Stripper Ejection and Double Ejection Molds.✓ Blow Molds.
✓ Standards Used	✓ HASCO, CUMSA, MISUMI, MEUSBURGER, SMC, etc.,
✓ Hot Runner Systems	✓ Mold Masters.

DESIGN CAPABILITY



MANUFACTURING



CNC EDM
GF - FORM20 - 1 No.



EDM
CHMER- 2 No's.

MANUFACTURING



CNC MILLING

BFW – BMV70 – 1 No.



CNC MILLING

BFW – BMV60 – 1 No.



CNC MILLING

BFW – BMV65 – 1 No.

MANUFACTURING



CNC MILLING
HASS - VF1 - 1 No.



CNC MILLING
HASS - VF2 - 1 No.



MANUFACTURING



CNC MILLING
HASS - VM6 - 2 No's

CNC MILLING
HASS - VM3 - 1 No.



MANUFACTURING



CNC MILLING
MAKINO – S56 – 1 No.



CNC MILLING
MAKINO – PS95 – 1 No.

MANUFACTURING



CNC TURNING
ACE – 1 No.



CNC MILLING
HASS – MINIMILL – 1 No.

MANUFACTURING



DEEP HOLE DRILLING MACHINE – LOCH – 1 No.

INSPECTION



COORDINATE MEASURING MACHINE – ZEISS – 1 No.



MANUFACTURING



CONFIDENTIAL

ANY REPRODUCTION OR DISSEMINATION STRICTLY PROHIBITED



**MANUFACTURING @ Parent
company – Unit-1**

CNC WIRE CUT



LASER 600 5AX



CNC WIRE EDM



MOULD TRIAL CAPABILITY @ UNIT-2

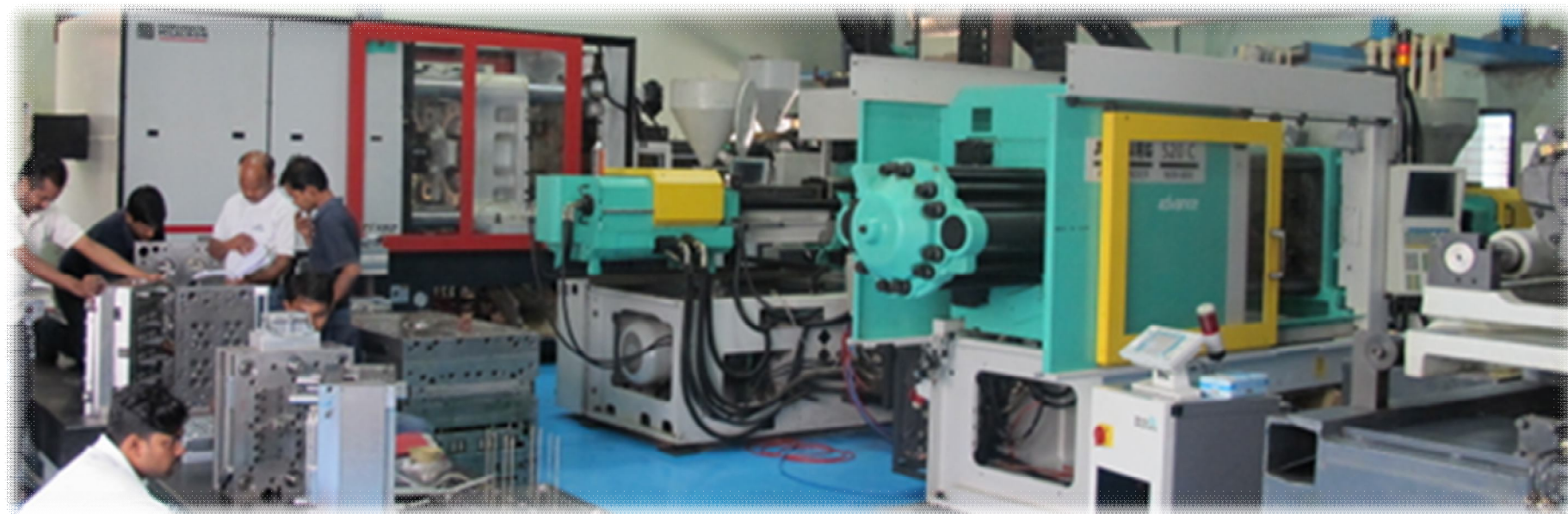

Machinery List.



CNC Vertical Milling Machine Centre.						
MACHINE	AXIS	SPINDLE SPEED	TRAVEL AREA	TOOL CAPACITY	MAKE	QTY
PS-95	X,Y,Z	14,000 RPM	900*500*550	30	MAKINO	1No
S-56	X,Y,Z	13,000 RPM	900*500*450	25	MAKINO	1No
VM-6	X,Y,Z	15000 RPM	1626*813*762	25	HAAS	2No's
VM-3	X,Y,Z	12,000 RPM	1016*660*635	25	HAAS	1No
VF-1	X,Y,Z	8100 RPM	508*406*508	24	HAAS	1No
VF-2	X,Y,Z	8100 RPM	750*400*500	24	HAAS	1No
MINI MILL	X,Y,Z	6000 RPM	406*305*254	10	HAAS	1No
BMV-70TC20	X,Y,Z	6000RPM	1600*910*810	24	BFW	1No
BMV-65TC20	X,Y,Z	8000RPM	1280*700*650	24	BFW	1No
BMV-60T20	X,Y,Z	8000RPM	1050*610*610	24	BFW	1No
Total :						11 No's.
CNC Turning Machining Centre						
Description			Make			Qty
CNC-Turning			ACE- Micromatic			1No

Machinery List.



Description	Make	Qty
EDM		
Form 200	GF(AGIE CHARMILES)	1No
50/N/C/M434C- Machine	CHMER	2 No's.
Co-ordinate Measuring Machine		
Contura G2	CARL ZEISS	1No
Gun Drilling Machining Centre		
Deep hole drilling machine	LOCH	1No
Sand Blasting Machine		
Sand Blasting Machine	MEC-SHOT	1No
Conventional Machines		
Surface Grinding Machine- Working Area (1500mm * 700mm)	PERFECT	1 No.
Surface Grinding Machine- Working Area (1500mm * 700mm)	PERFECT	1 No.
Surface Grinding Machine- Working Area (800mm * 400mm)	PERFECT	1 No.
Surface Grinding Machine- Working Area (450mm * 150mm)	PRAGA	1 No.
Surface Grinding Machine- Working Area (450mm * 150mm)	JONES-SHIPMAN	1 No.
Surface Grinding Machine- Working Area (300mm * 100mm)	HMT	1 No.
Cylindrical Grinding Machine	MICROMATIC	2 No's.
Convention Milling Machine	ESTEAM	2 No's.
Radial Drilling Machine	HMT	1 No.
Radial Drilling Machine	RMS	1 No.
Lathe Machine	South Brand	1 No
Block up Machine	H.ERNAULT SOMUA	2 No's.

SOME OF OUR HIGH CAVITATION INJECTION MOLDS DEVELOPMENTS



72-Cavity Unscrewing Mold for Harpic Cap.

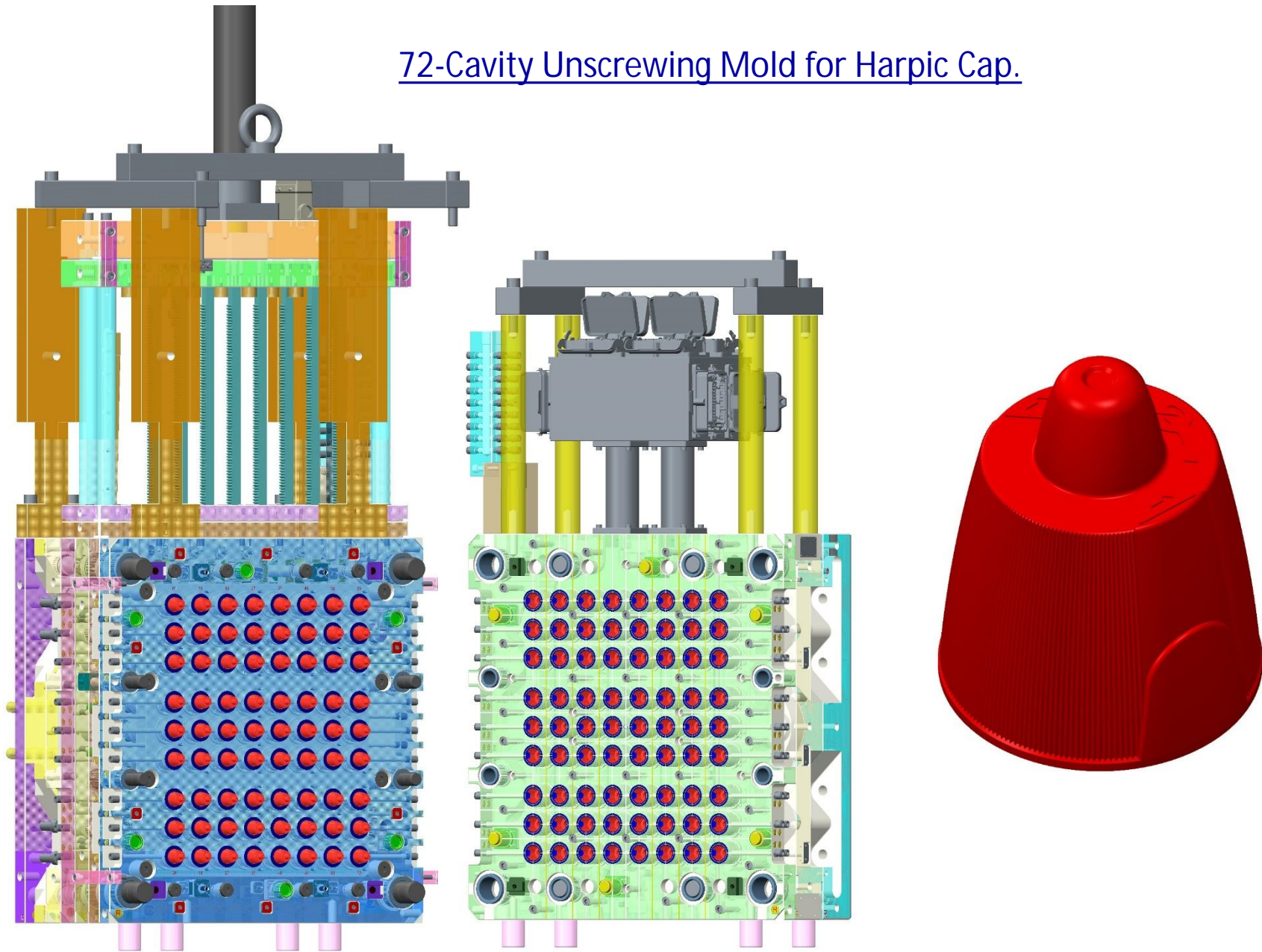

SOME OF OUR HIGH CAVITATION INJECTION MOLDS DEVELOPMENTS



48-Cavity Cap Mold for Iodex 8gm.

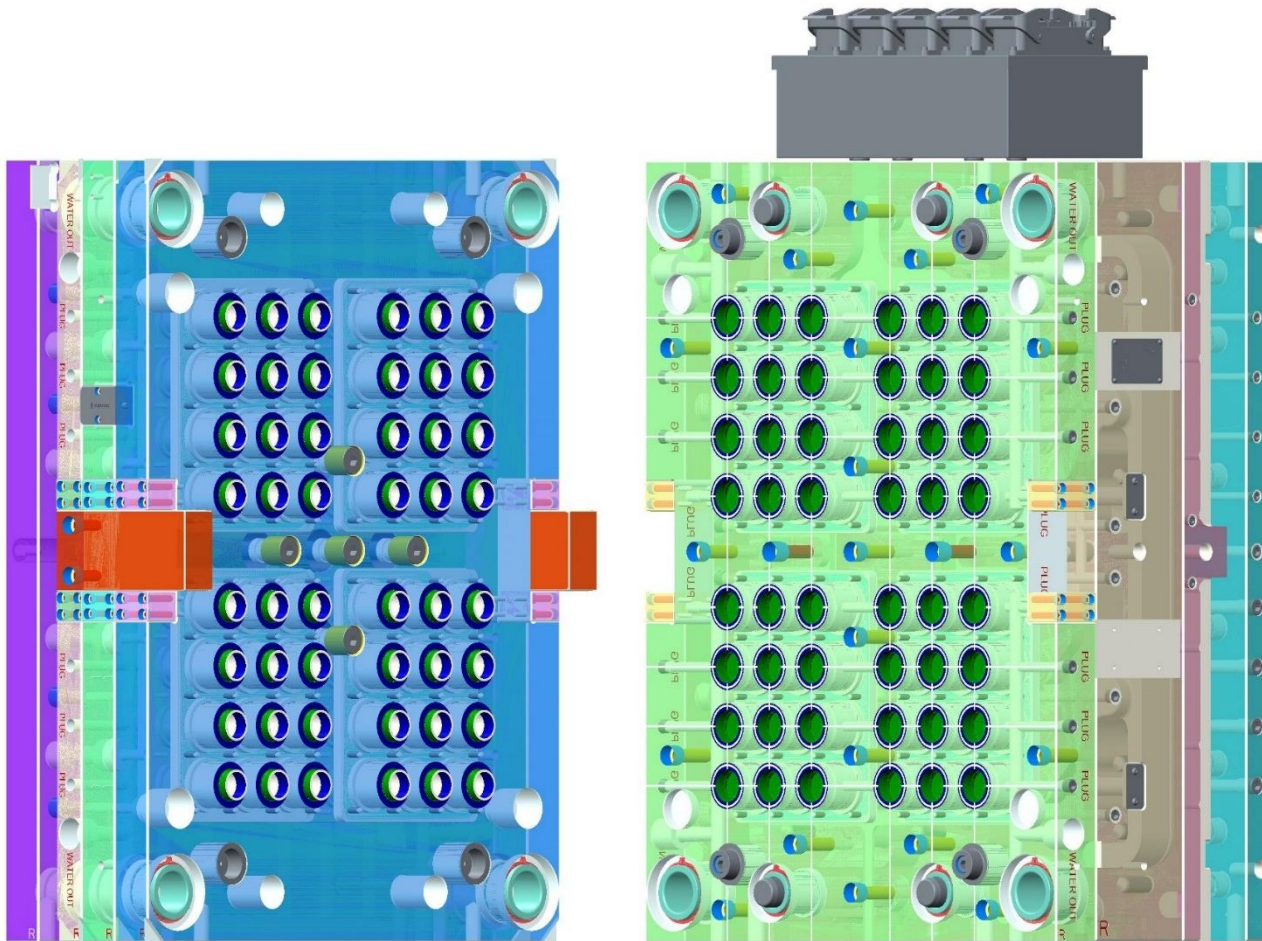

SOME OF OUR HIGH CAVITATION INJECTION MOLDS DEVELOPMENTS



24-Cavity Jar Mold for Iodex 8gm.

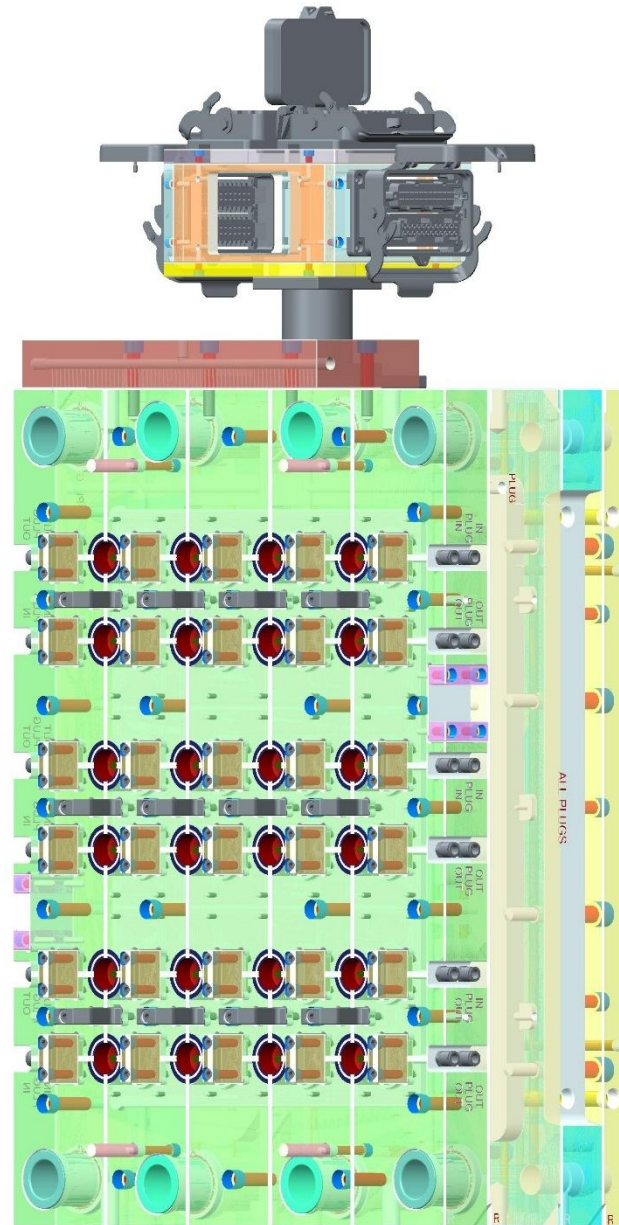
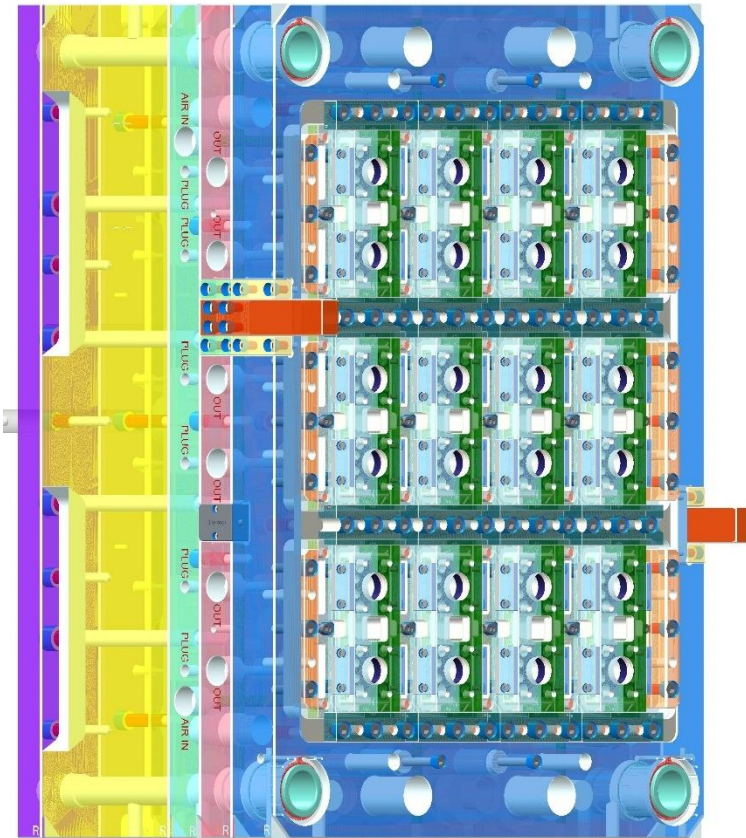

SOME OF OUR HIGH CAVITATION INJECTION MOLDS DEVELOPMENTS



24-Cavity Cap Mold for Iodex 16gm.

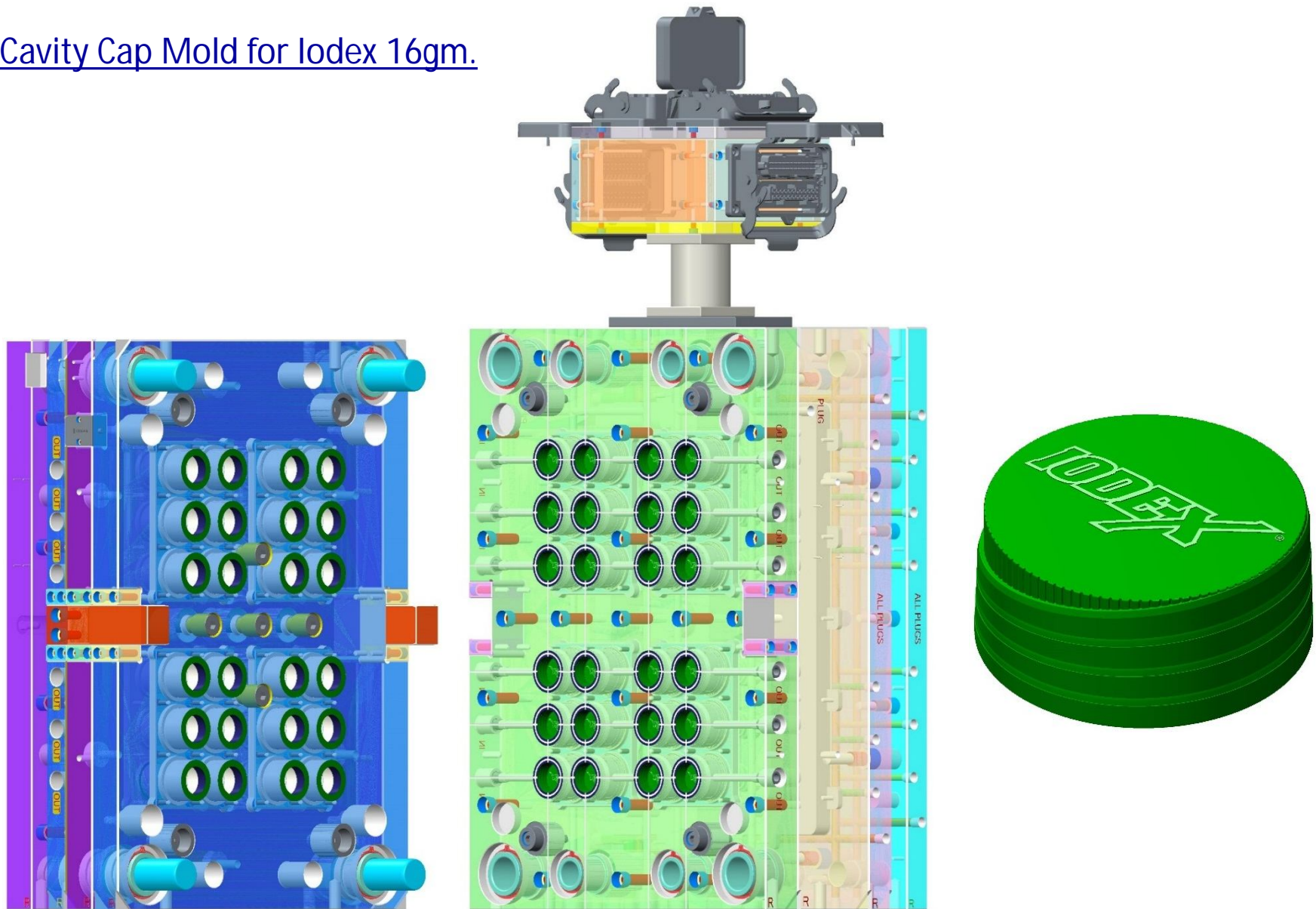

SOME OF OUR HIGH CAVITATION INJECTION MOLDS DEVELOPMENTS



24-Cavity Jar Mold for Iodex 16gm.



SOME OF OUR HIGH CAVITATION INJECTION MOLDS DEVELOPMENTS



16-Cavity Unscrewing Cap Mold.

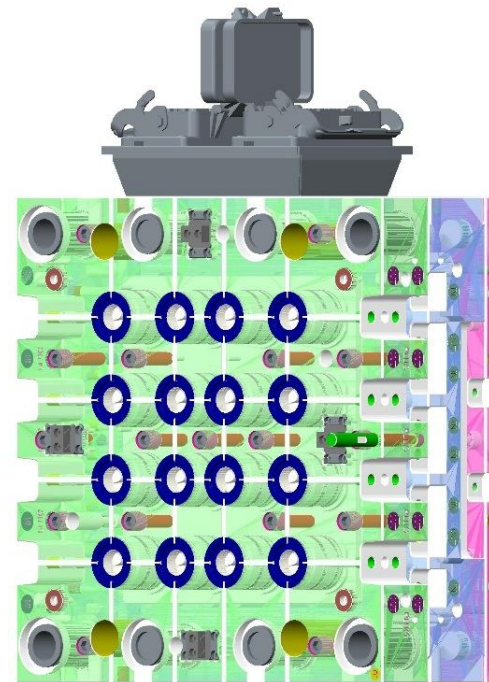
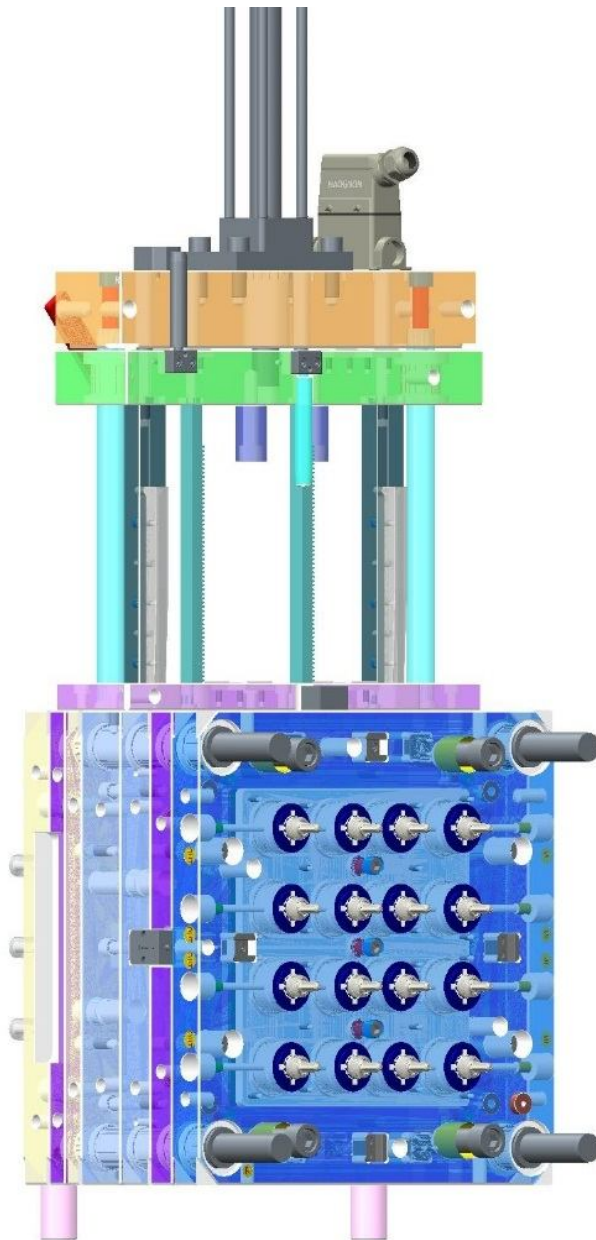

SOME OF OUR BLOW MOLD PICTURES.

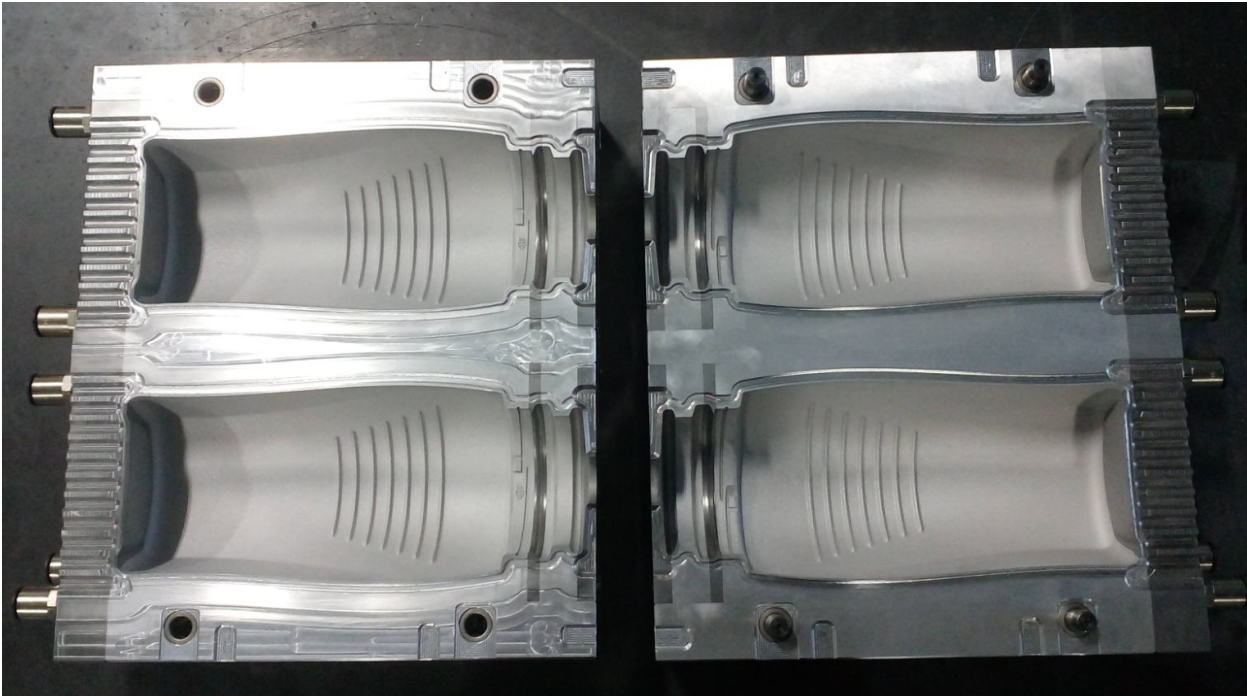

Horlicks 1Kg Jar – 2+2 Cavity
Mold.

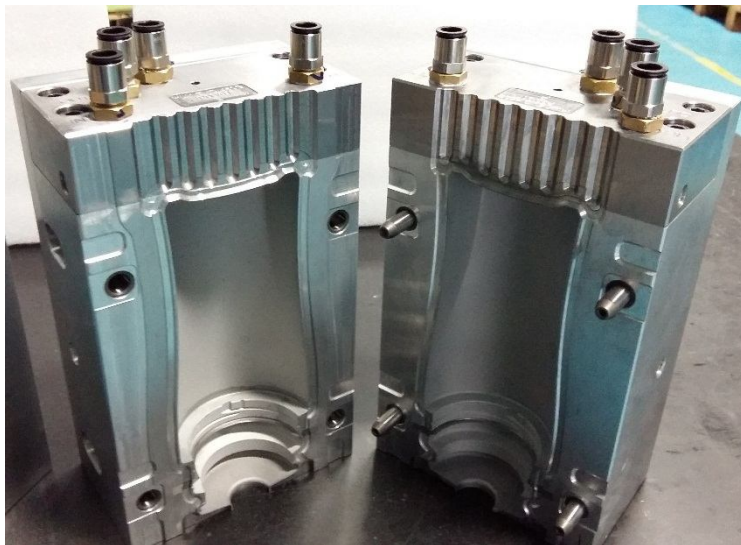

Horlicks 200gm Jar

SOME OF OUR BLOW MOLD PICTURES.

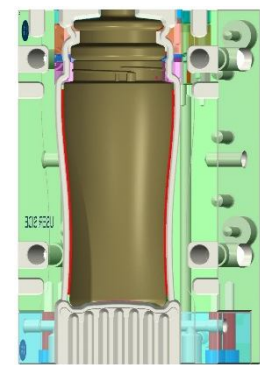
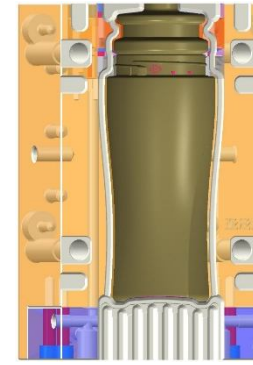
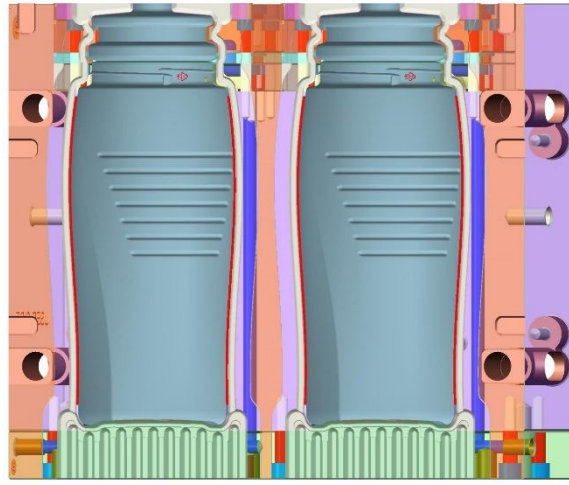
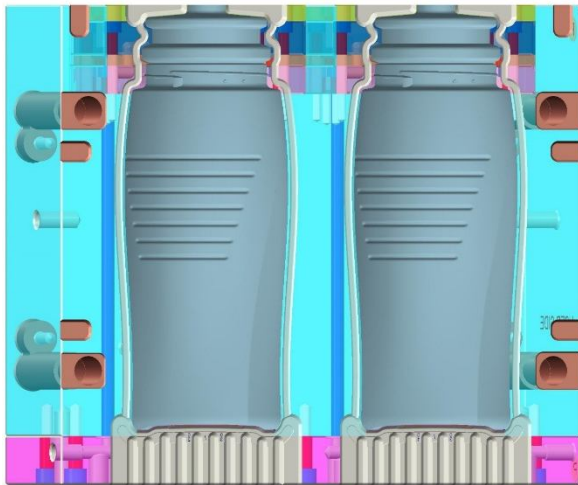

Horlicks 450gm Jar

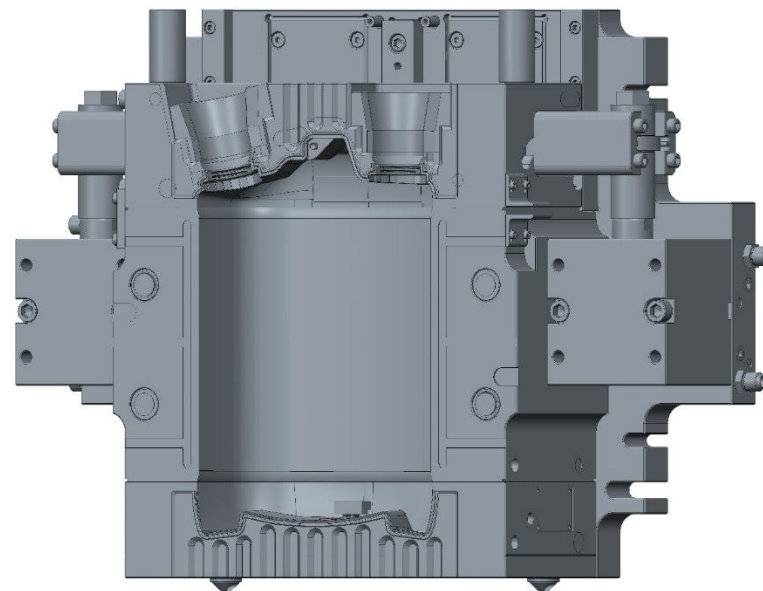
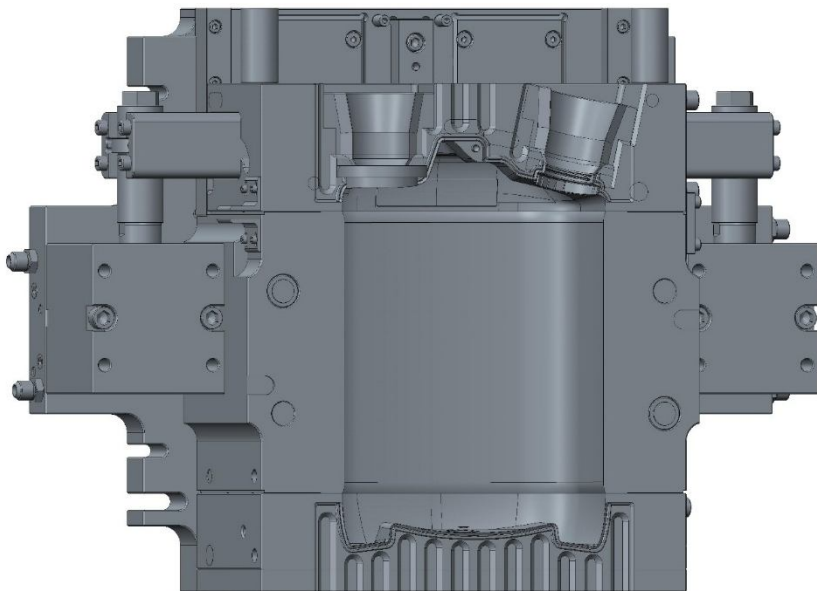

Horlicks 1.0 kg Jar – 2+2 Cavity Mold



25.0 Lit Can with Twin Neck.

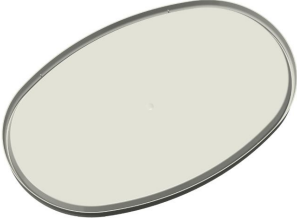
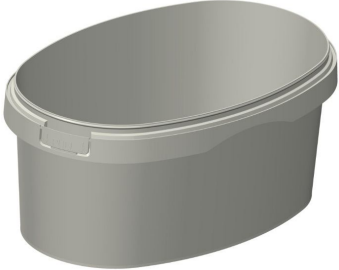

SOME OF OUR THIN WALL INJECTION MOLDS DEVELOPMENTS



Description	Product Image
02-Cavity Fully Hot Runner Mold for 1000ml Food Container	
02-Cavity Fully Hot Runner Mold for 1000ml Ice Cream Lid	
01-Cavity Fully Hot Runner Mold for 1000ml Ice Cream Jar	
02-Cavity Fully Hot Runner Mold for 500ml Ice Cream Jar	

SOME OF OUR THIN WALL INJECTION MOLDS DEVELOPMENTS

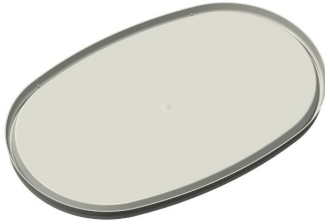
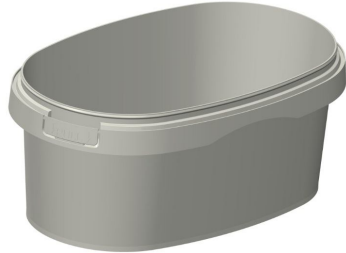
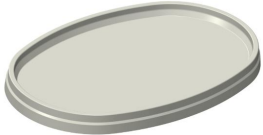

Description	Product Image
02-Cavity Fully Hot Runner Mold for 750ml Ice Cream Lid	
01-Cavity Fully Hot Runner Mold for 750ml Ice Cream Jar	
01-Cavity Fully Hot runner Mold for 130ml Ice cream Lid	
01-Cavity Fully Hot runner Mold for 130ml Ice cream Jar	

SOME OF OUR THIN WALL INJECTION MOLDS DEVELOPMENTS



1000ml Food Container 02-Cavity Mold.

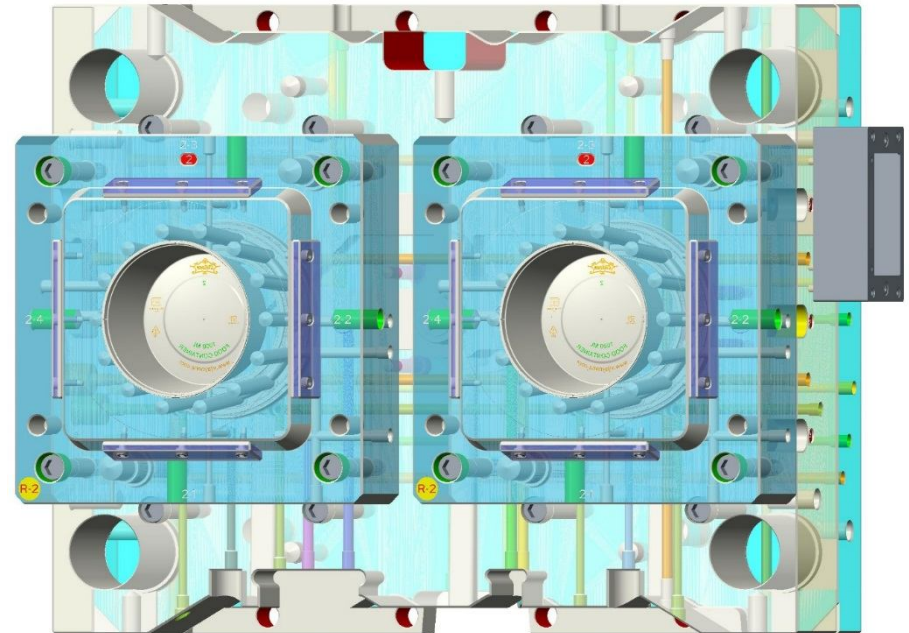
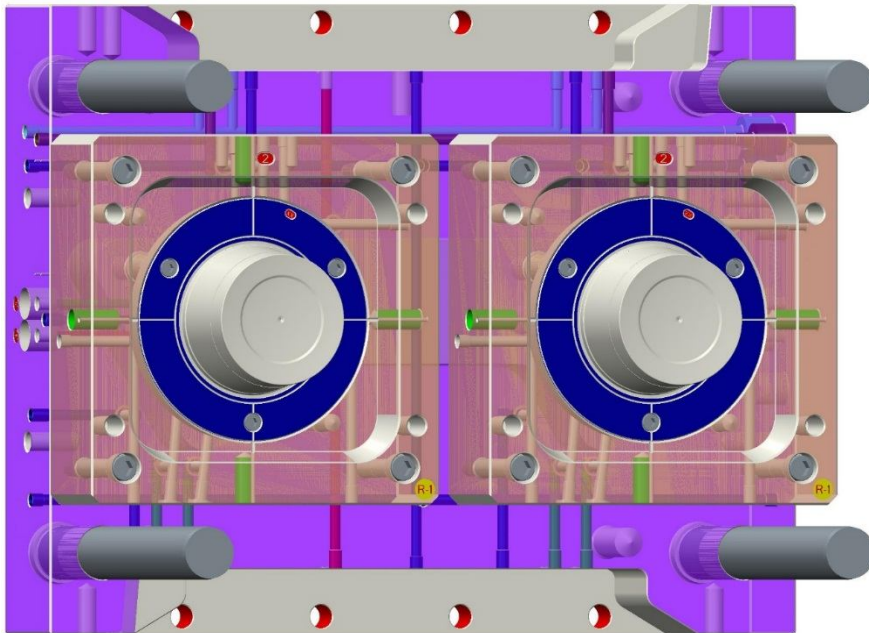

SOME OF OUR THIN WALL INJECTION MOLDS DEVELOPMENTS





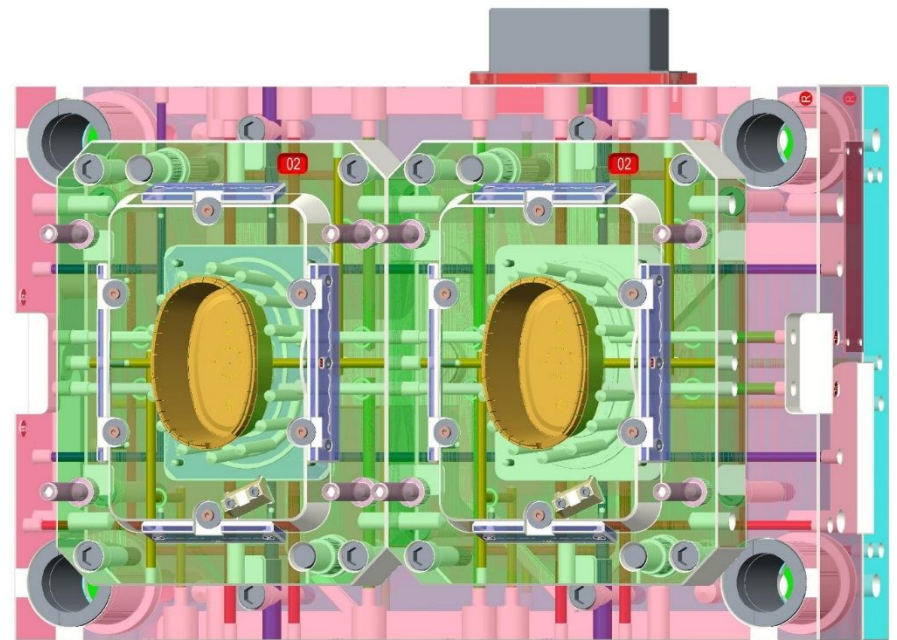
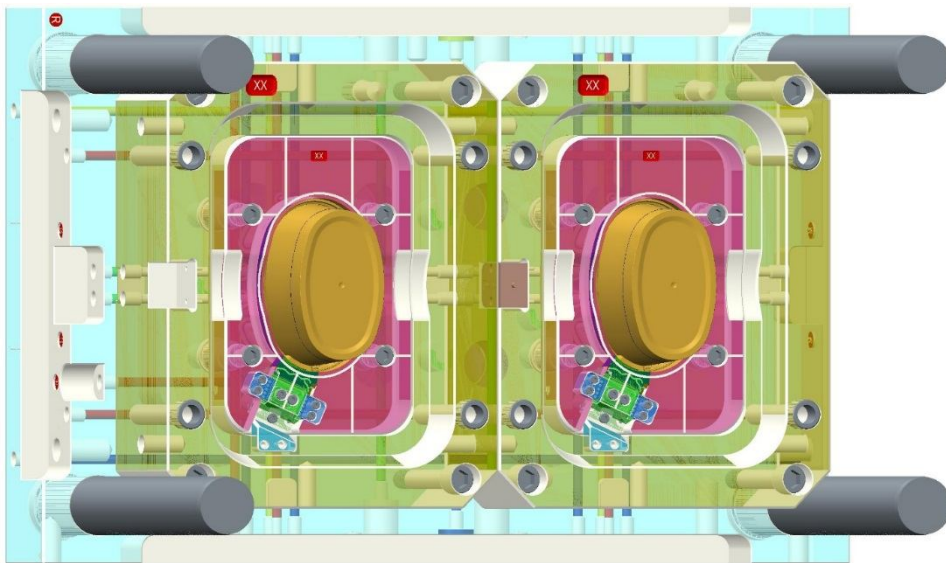

500ml Ice Cream Jar 02-Cavity Mold.



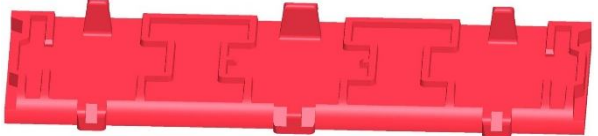

SOME OF OUR INJECTION MOLDS DEVELOPMENTS FOR ELECTRICAL COMPONENTS.



Description	Product Image
08-Cavity Mold for G2810 for 'Legrand'	 A 3D rendering of a pink, elongated, tapered electrical component. It has a small notch on the left side and a larger notch on the right side. The number 'A8' is printed in red on the left side.
08-Cavity Mold for G2128 for 'Legrand'	 A 3D rendering of a red, elongated electrical component with a complex, multi-cavity design. It has several rectangular protrusions and recessions along its length. The number 'A8' is printed in green on the right side.
08-Cavity Mold for G2129 for 'Legrand'	 A 3D rendering of a red, elongated electrical component with a complex, multi-cavity design. It has several rectangular protrusions and recessions along its length.
08-Cavity Mold for G2130 for 'Legrand'	 A 3D rendering of a red, elongated electrical component with a complex, multi-cavity design. It has several rectangular protrusions and recessions along its length. The number 'A8' is printed in green on the left side.

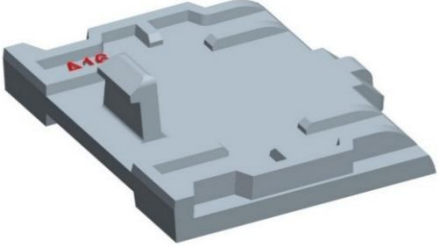

SOME OF OUR INJECTION MOLDS DEVELOPMENTS FOR ELECTRICAL COMPONENTS.

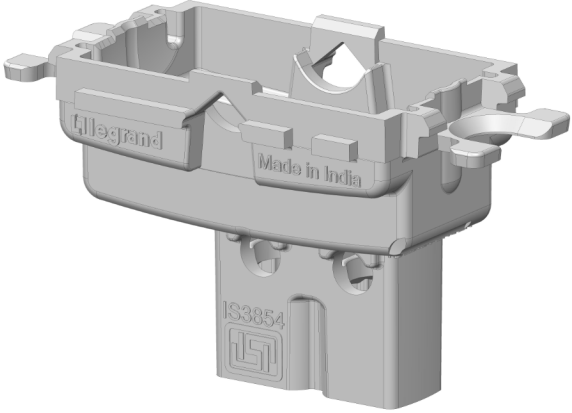

Description	Product Image
16-Cavity Mold for G2131 for 'Legrand'	
16-Cavity Mold for G2810 for 'Legrand'	
16-Cavity Mold for Switch Base for 'Legrand' <u>2 Molds</u>	

SOME OF OUR INJECTION MOLDS DEVELOPMENTS FOR ELECTRICAL COMPONENTS.



Description	Product Image
08-Cavity Mold for Riblock for <u>'A Raymond'</u>	
16-Cavity Mold for Small Retainer for <u>'A Raymond'</u>	
16-Cavity Mold for Big Retainer for <u>'A Raymond'</u>	

SOME OF OUR INJECTION MOLDS DEVELOPMENTS FOR ELECTRICAL COMPONENTS.

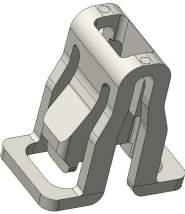
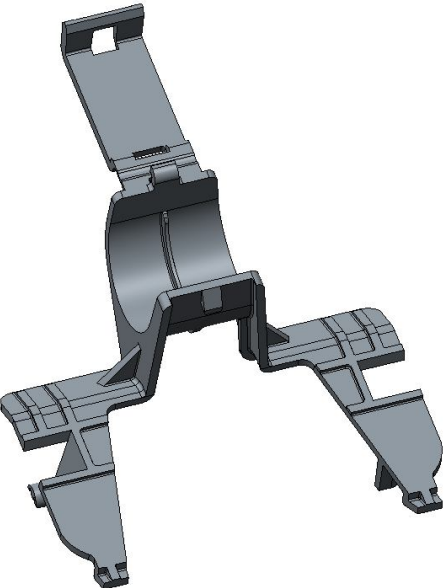

Description	Product Image
16-Cavity Mold for Panel Clip for <u>'A Raymond'</u>	 A 3D CAD model of a panel clip, rendered in a light grey color. It has a U-shaped profile with a central notch and a small rectangular feature on the top surface.
1-Cavity Mold for Pipe Clip for <u>'A Raymond'</u>	 A 3D CAD model of a pipe clip, rendered in a light grey color. It features a complex, multi-ported design with several flanges and a central vertical section.

SOME OF OUR INJECTION MOLDS DEVELOPMENTS FOR ELECTRICAL COMPONENTS.



Description	Product Image
04-Cavity Mold for CB50530 for <u>'L & T'</u>	
04-Cavity Mold for CB50529 for <u>'L & T'</u>	
01-Cavity Mold for Housing for <u>'L & T'</u>	

SOME OF OUR INJECTION MOLDS DEVELOPMENTS FOR ELECTRICAL COMPONENTS.

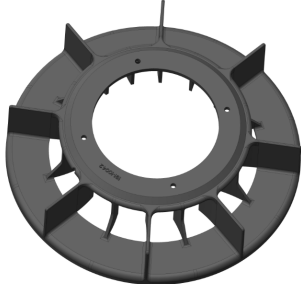
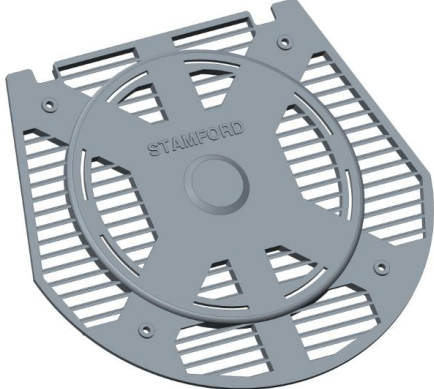
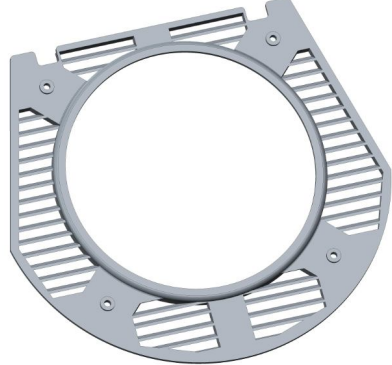

Description	Product Image
01-Cavity Mold for Fan cover for 'Varsa Plastics'	
01-Cavity Mold for NDE Cover for 'Varsa Plastics'	
01-Cavity Mold for NDE Cover-2 for 'Varsa Plastics'	

SOME OF OUR INJECTION MOLDS DEVELOPMENTS FOR ELECTRICAL COMPONENTS.



16-Cavity Mold for Switch Base for Legrand.

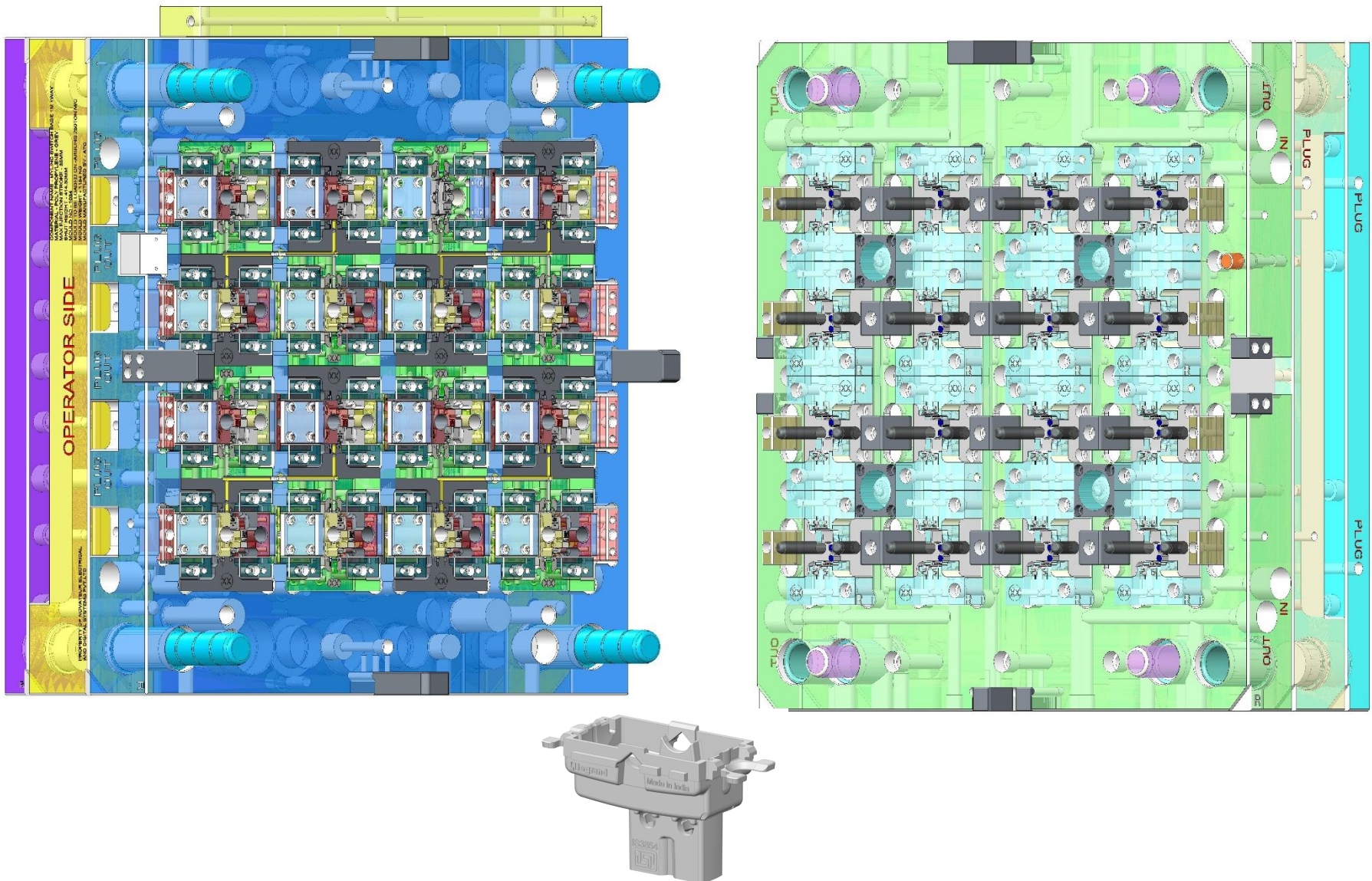

SOME OF OUR INJECTION MOLDS DEVELOPMENTS FOR ELECTRICAL COMPONENTS.



08-Cavity Mold for G2128 for Legrand.

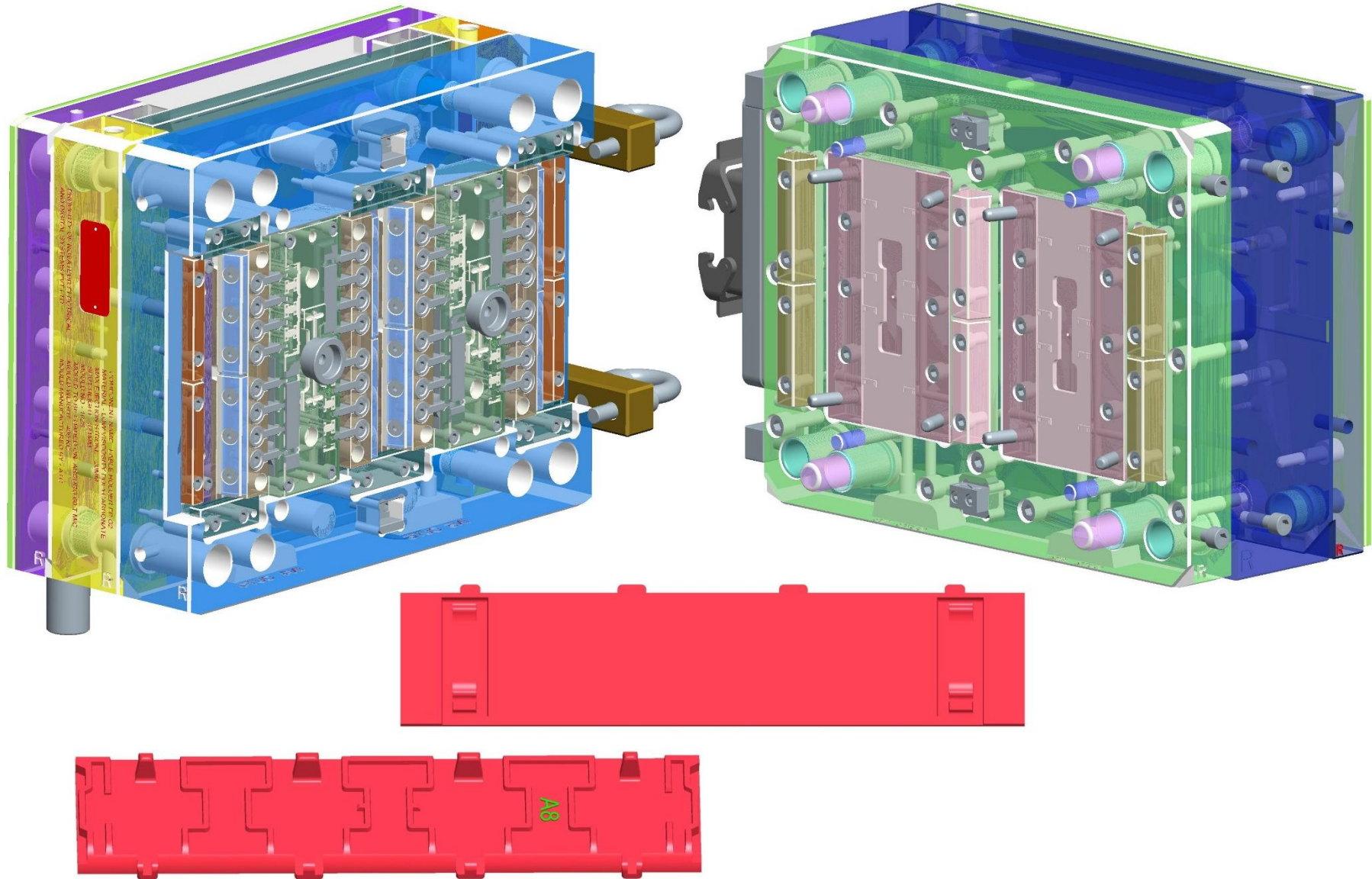

SOME OF OUR INJECTION MOLDS DEVELOPMENTS FOR ELECTRICAL COMPONENTS.



16-Cavity Mold for Retainer (Big).

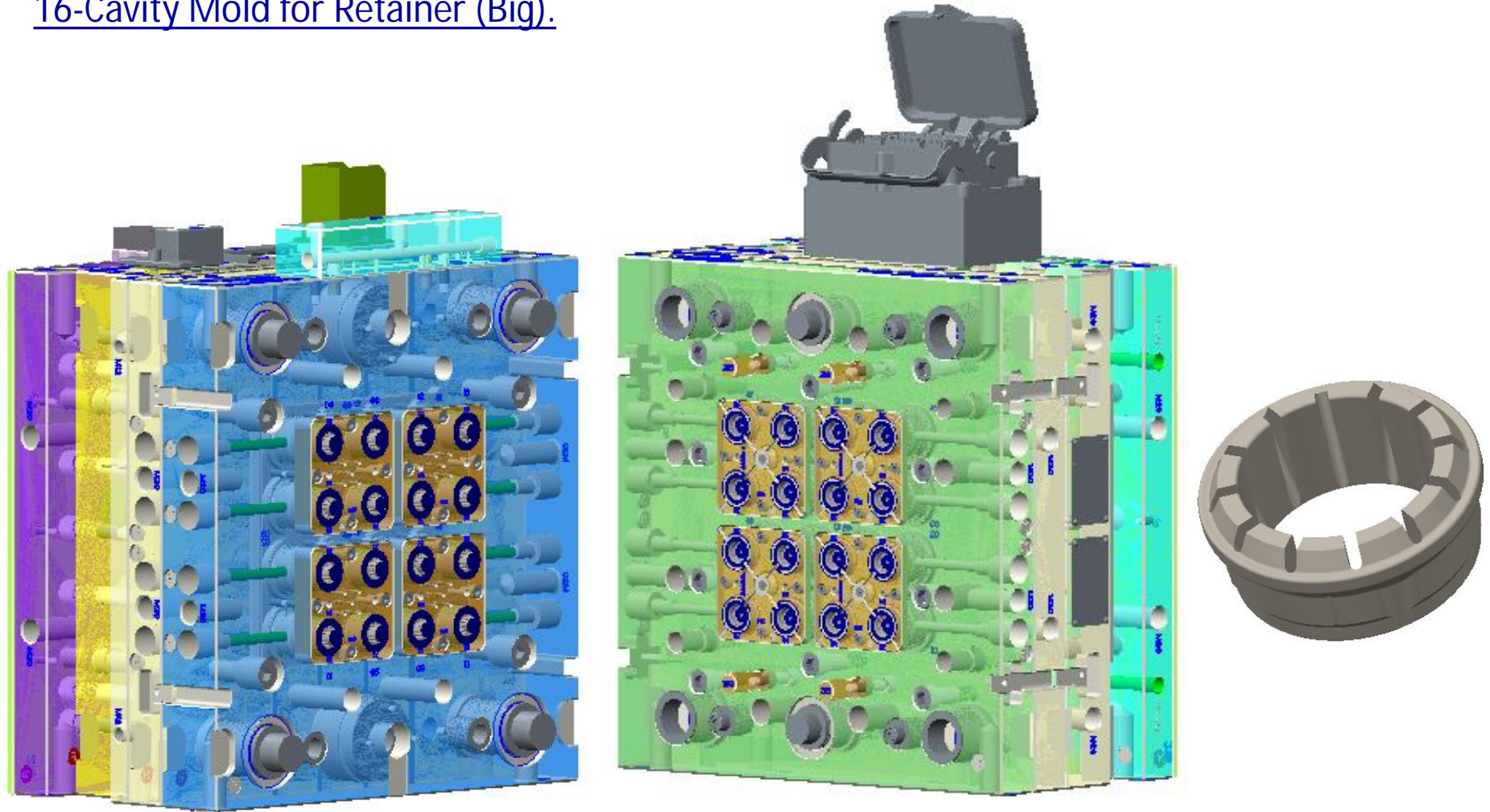

SOME OF OUR INJECTION MOLDS DEVELOPMENTS FOR ELECTRICAL COMPONENTS.



16-Cavity Mold for G2131 for Legrand.

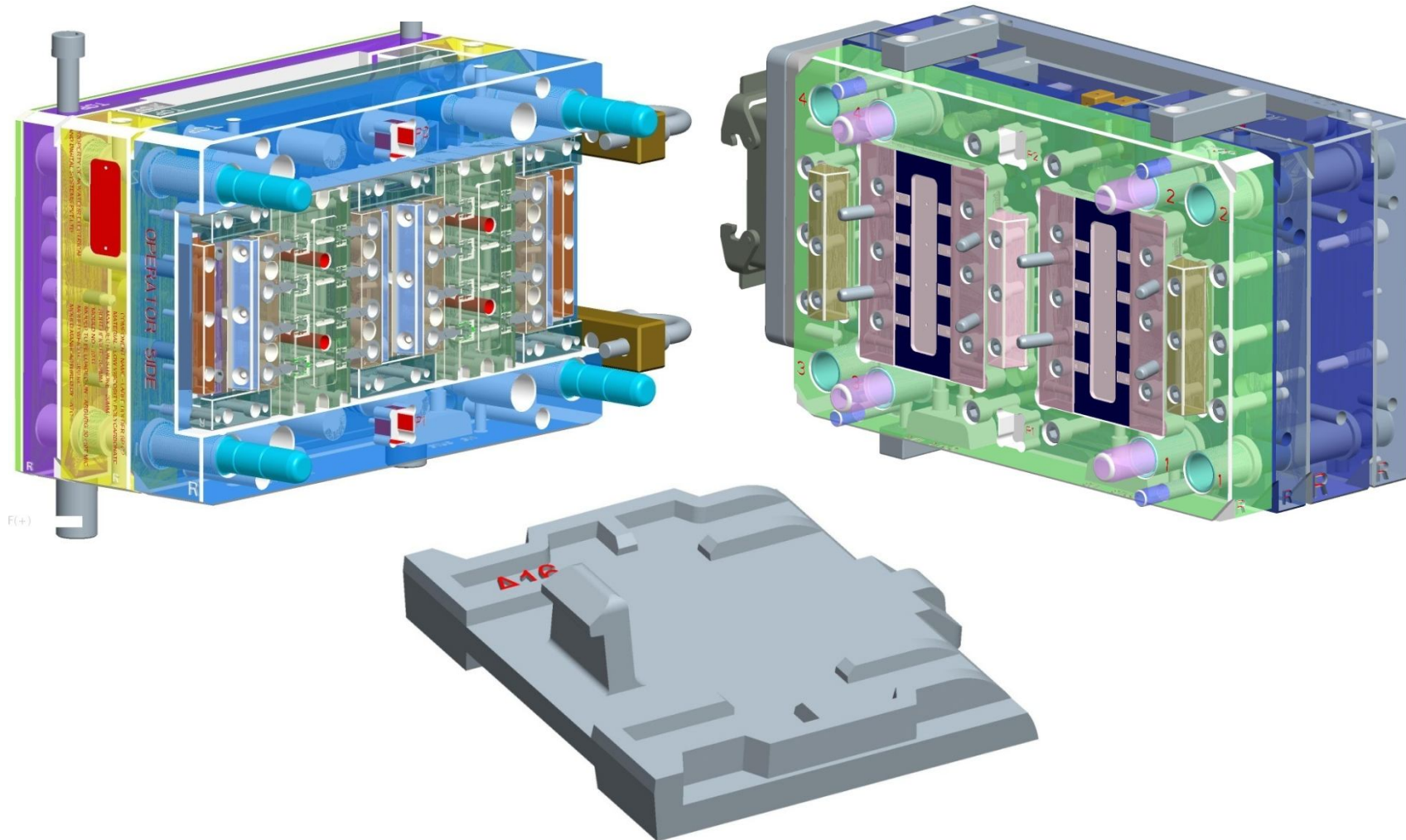

SOME OF OUR INJECTION MOLDS DEVELOPMENTS FOR ELECTRICAL COMPONENTS.



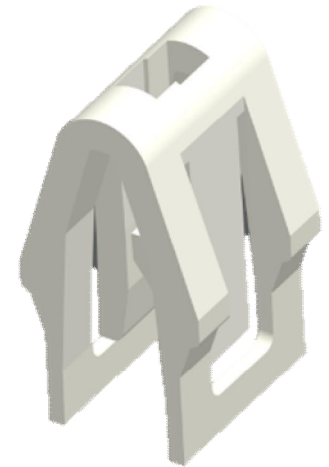

08-Cavity Mold for Rib Lock.



SOME OF OUR INJECTION MOLDS DEVELOPMENTS FOR TOYS

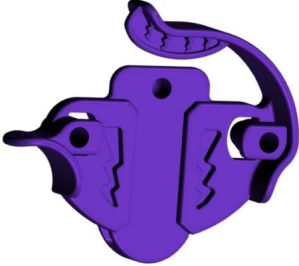

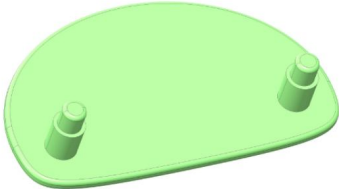
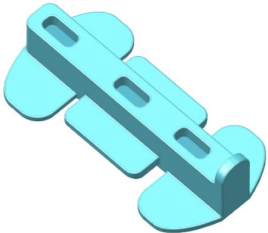
Description	Product Image
12-Cavity Mold for Launcher for 'Kinder Joy'	 A 3D rendered model of a purple toy launcher, shaped like a fish with a curved tail and a small hook-like protrusion on its side.
24-Cavity Mold for Half Bracelet for 'Kinder Joy'	 A 3D rendered model of a yellow, curved bracelet with a textured, ribbed surface.
24-Cavity Mold for Scorpion Cover for 'Kinder Joy'	 A 3D rendered model of a light green, flat, irregularly shaped cover with two small cylindrical protrusions on its surface.
24-Cavity Mold for Mirror Base for 'Kinder Joy'	 A 3D rendered model of a light blue, rectangular mirror base with two circular cutouts and a small protrusion on one end.

SOME OF OUR INJECTION MOLDS DEVELOPMENTS FOR TOYS



Description	Product Image
16-Cavity Mold for Disk for 'Kinder Joy'	 A 3D rendering of a light green plastic disk with a central knob and a circular hole in the center.
16-Cavity Mold for Magic Mirror for 'Kinder Joy'	 A 3D rendering of a red plastic mirror with a rectangular shape and a small handle at the bottom.
32-Cavity Mold for Brush Holder for 'Kinder Joy'	 A 3D rendering of a grey plastic brush holder with a cylindrical shape and a central hole.

SOME OF OUR MOLD BASE PICTURES.

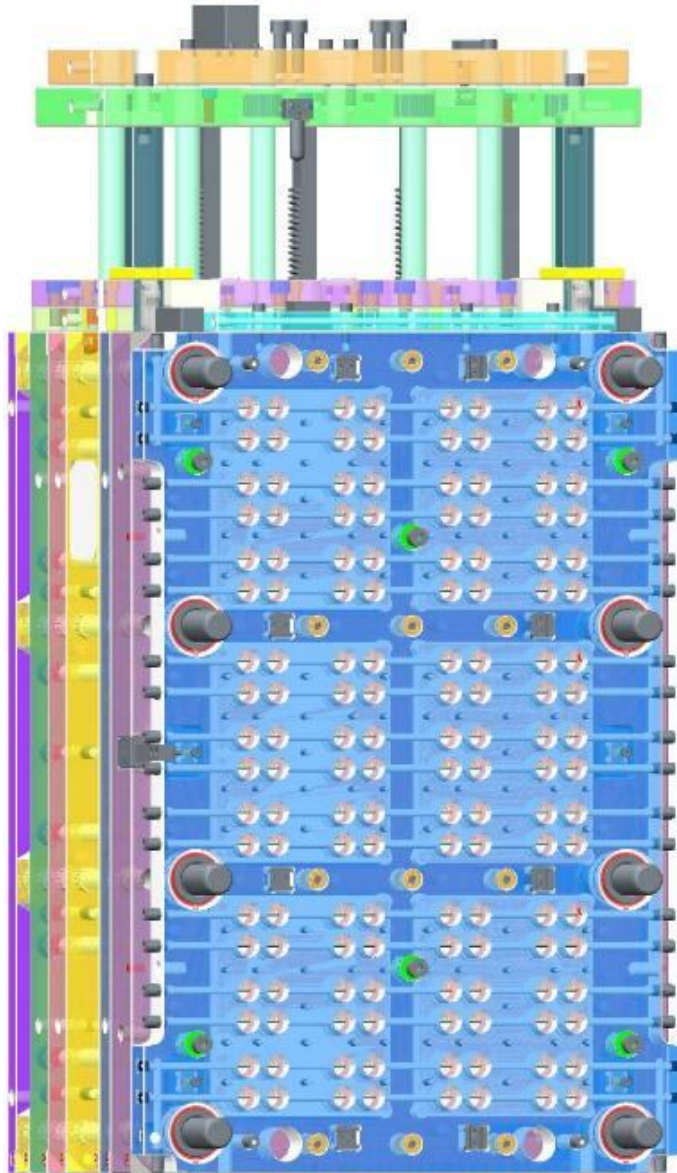

144 Cavity Mold Base for Fez Cap.

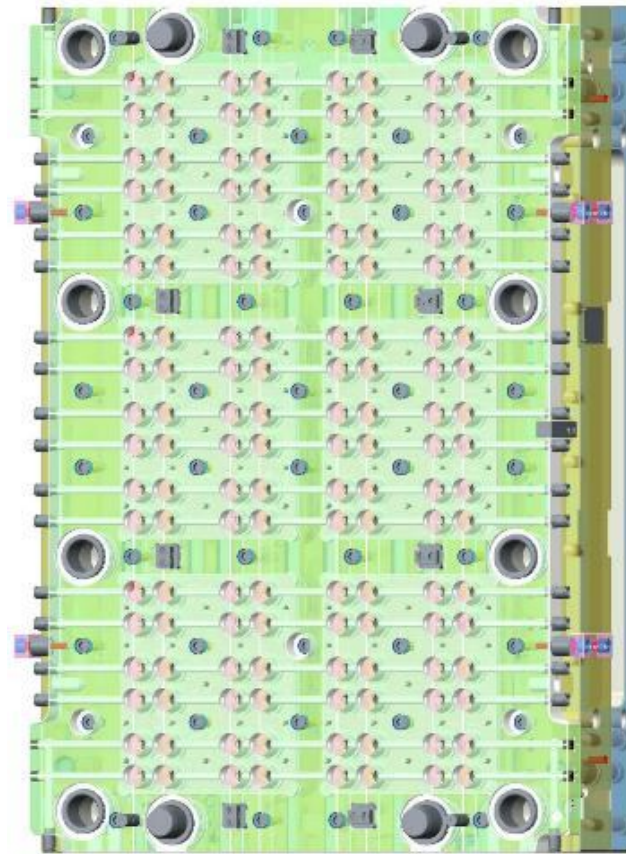

SOME OF OUR MOLD BASE PICTURES.



96 Cavity Mold Base for Emami Bottom

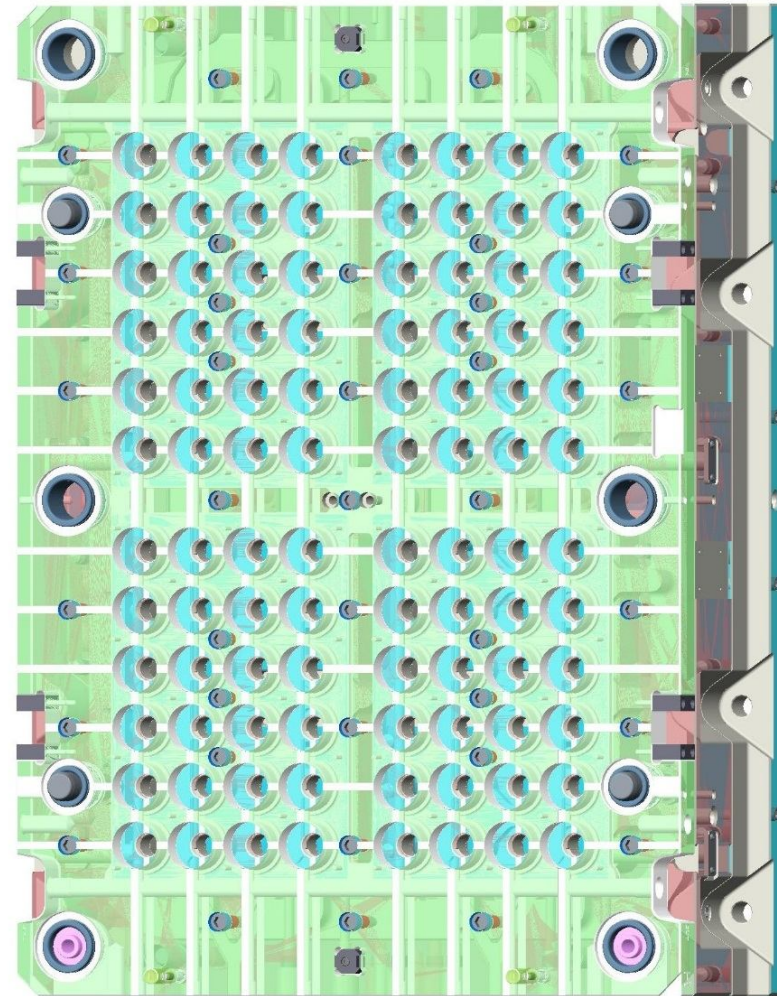
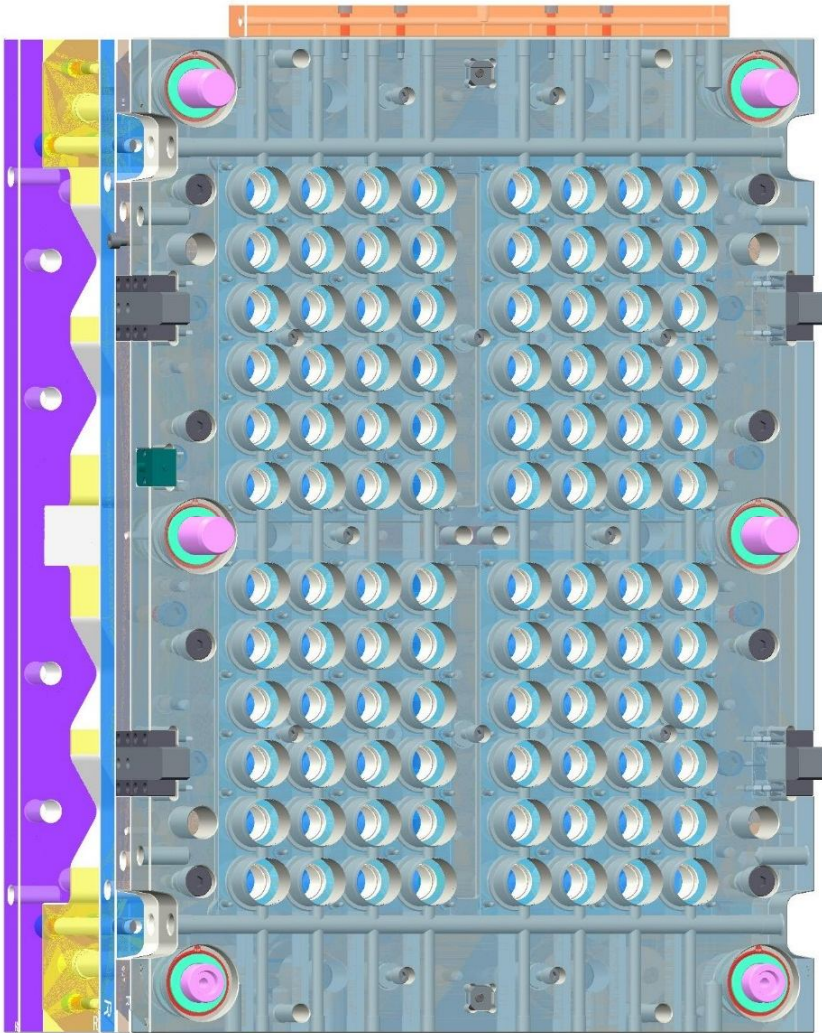

SOME OF OUR MOLD BASE PICTURES.

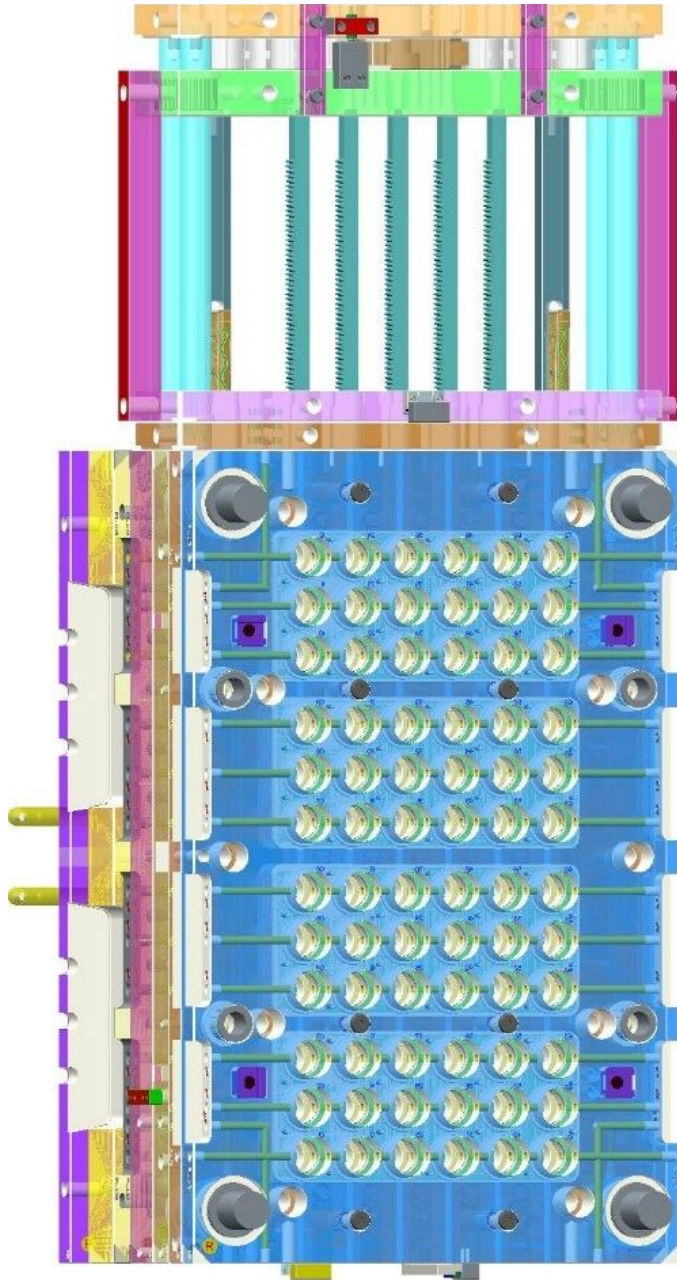

72 Cavity Mold Base for Harpic Slim Cap.

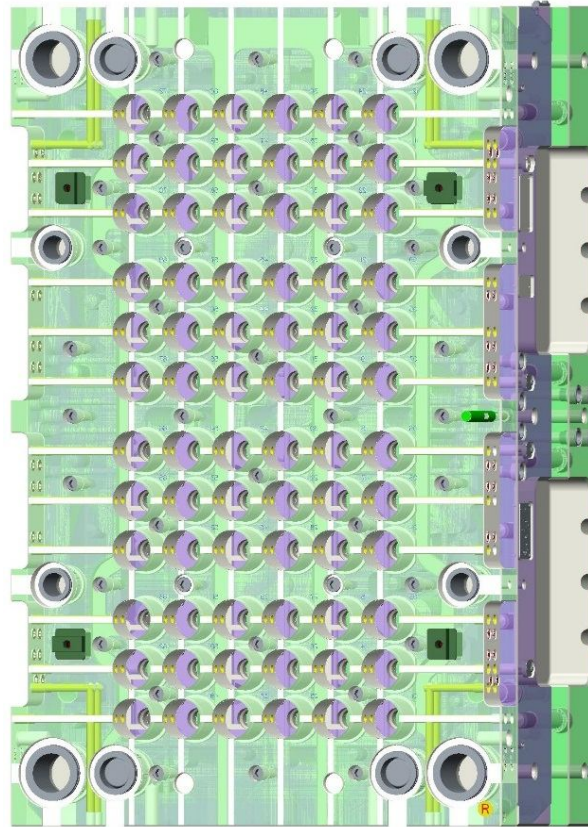

SOME OF OUR MOLD BASE PICTURES.



64 Cavity Mold Base for Oxidiser Cap.

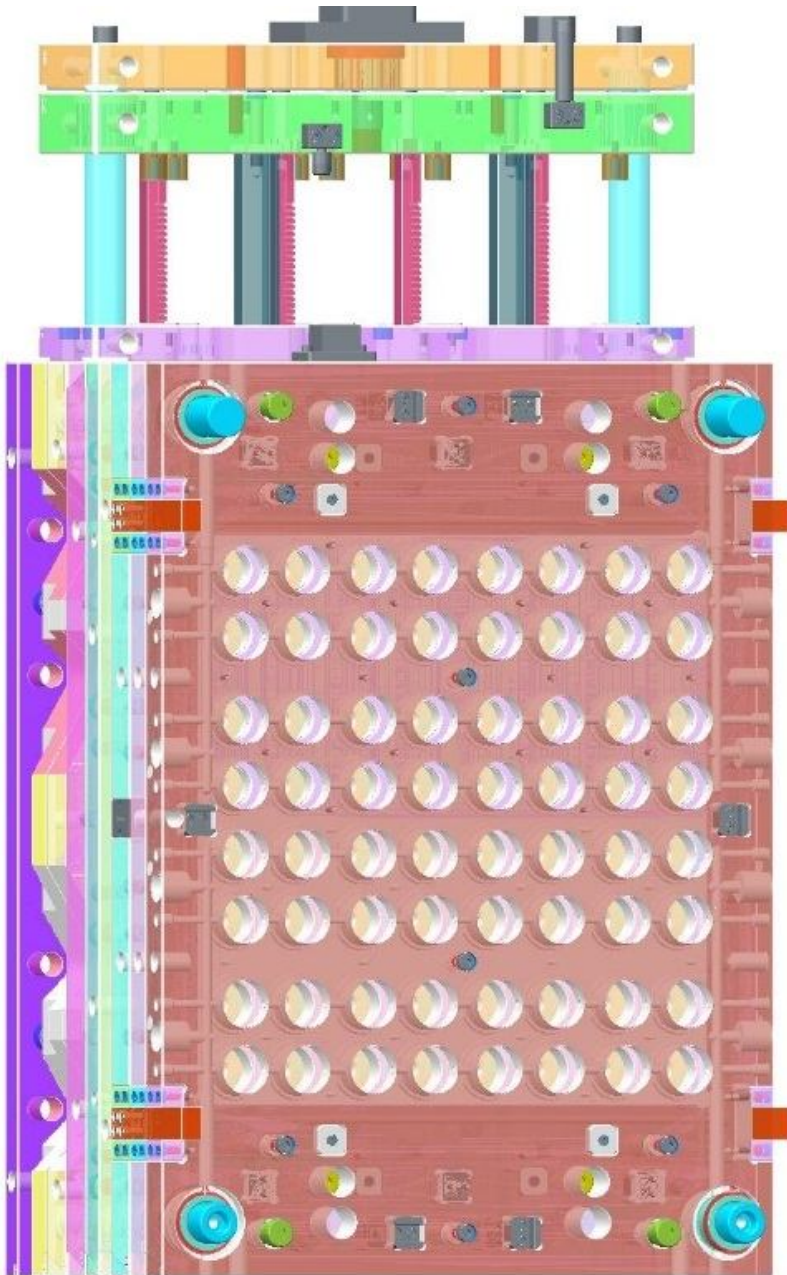

SOME OF OUR MOLD BASE PICTURES.

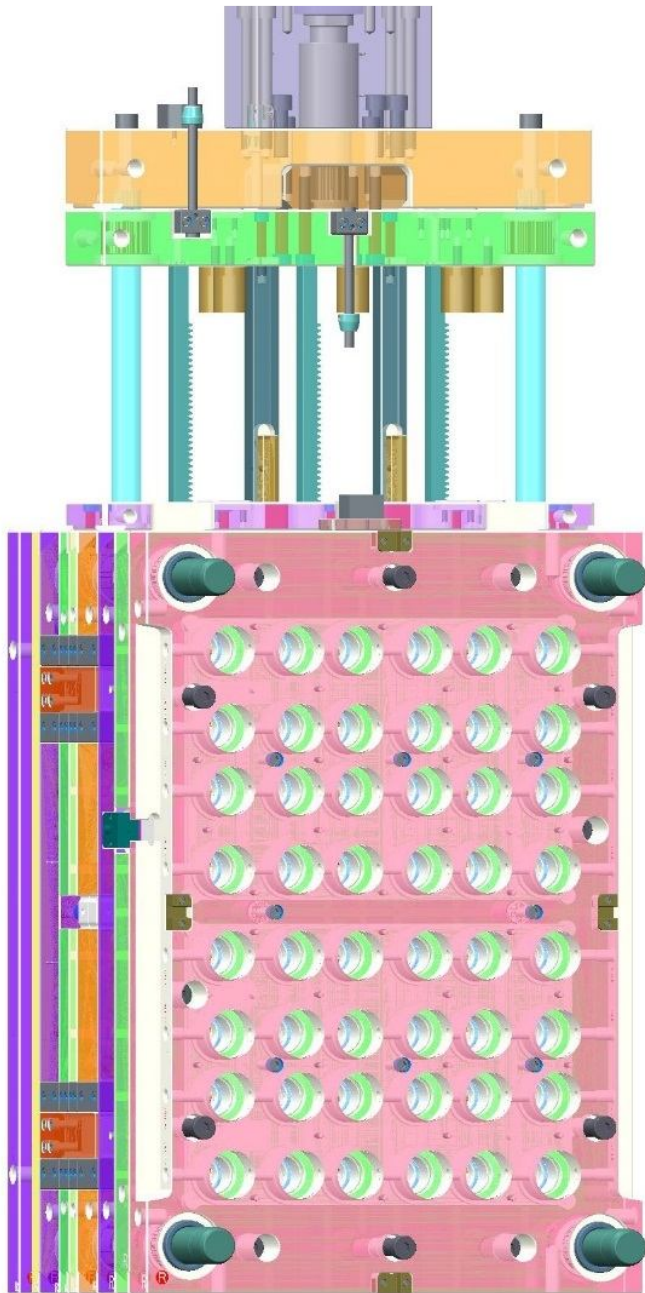

48 Cavity Mold Base for Air Wick Cap.



SOME OF OUR MOLD BASE PICTURES.



32 Cavity Mold Base for Dermicool Cap.

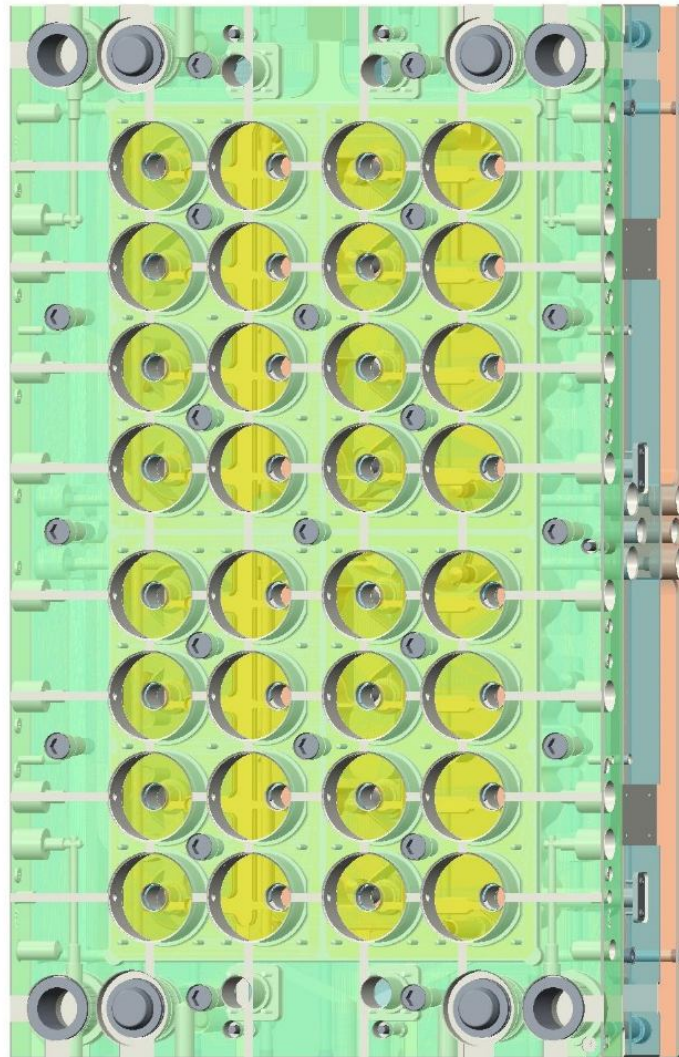
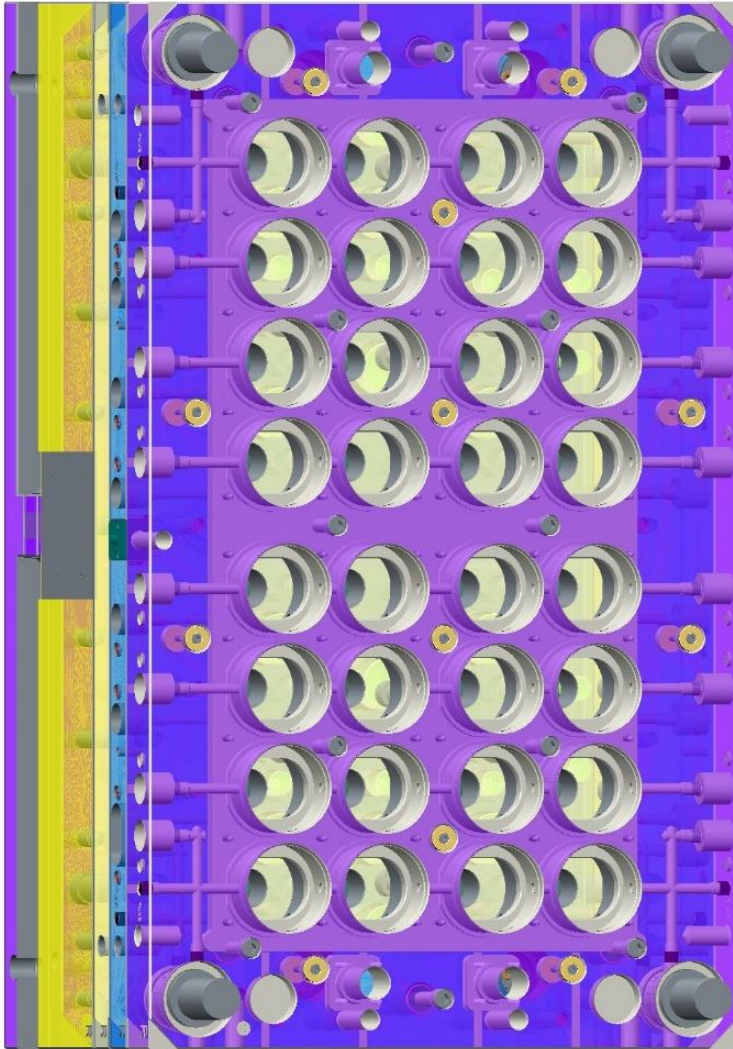

SOME OF OUR MOLD BASE PICTURES.



16 Cavity Bi- Injection with IMC Mold Base.

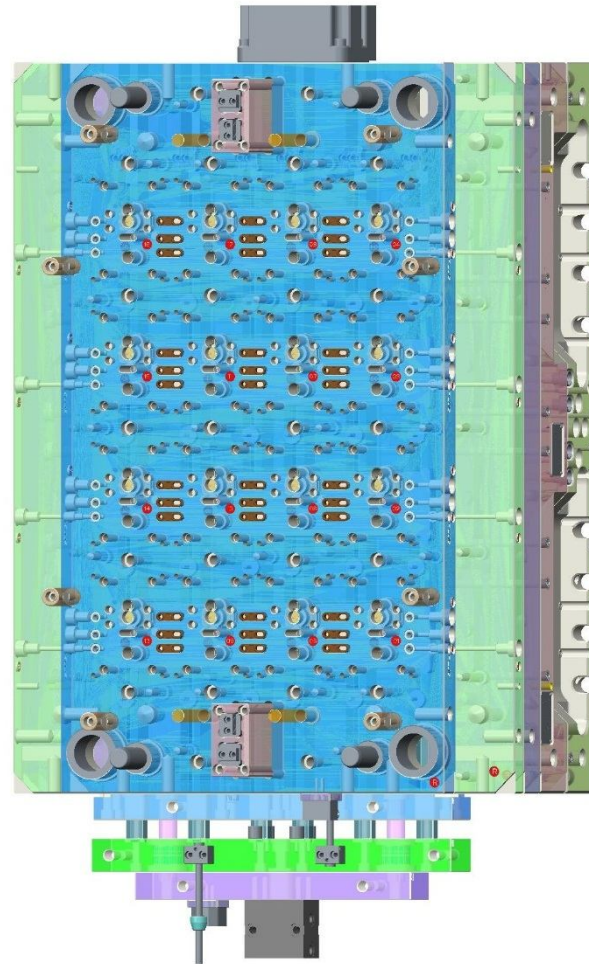
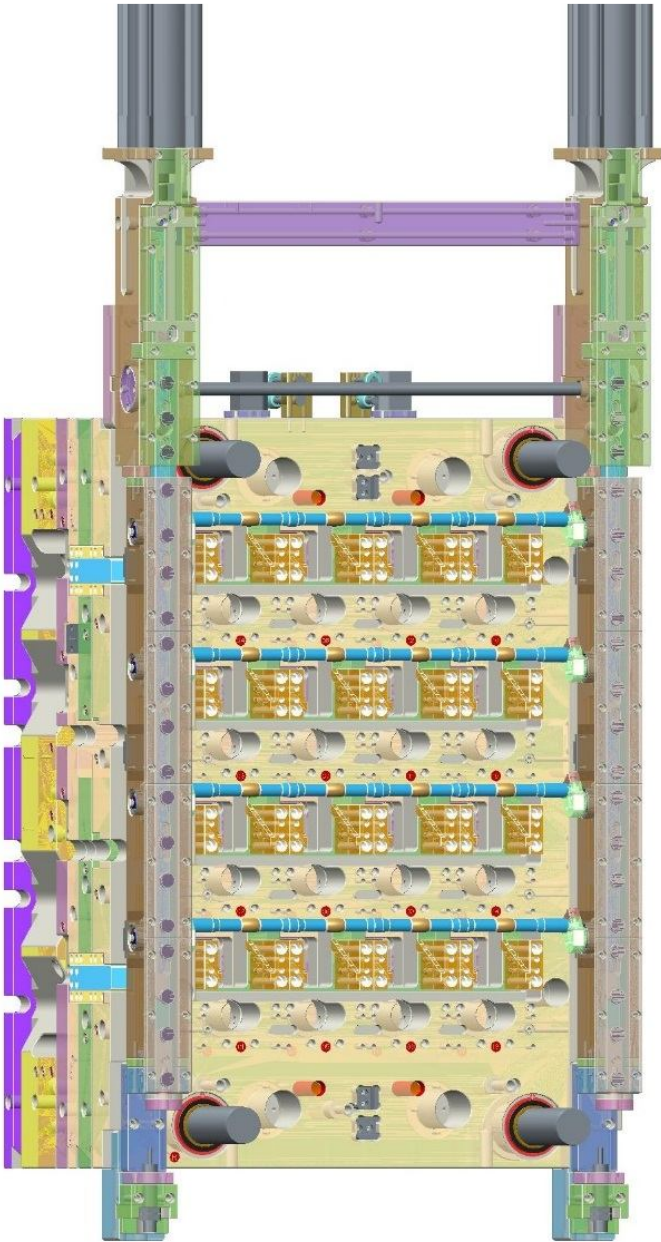

SOME OF OUR MOLD BASE PICTURES.



24 Cavity Bi- Injection with IMC Mold Base for 40mm Cap.

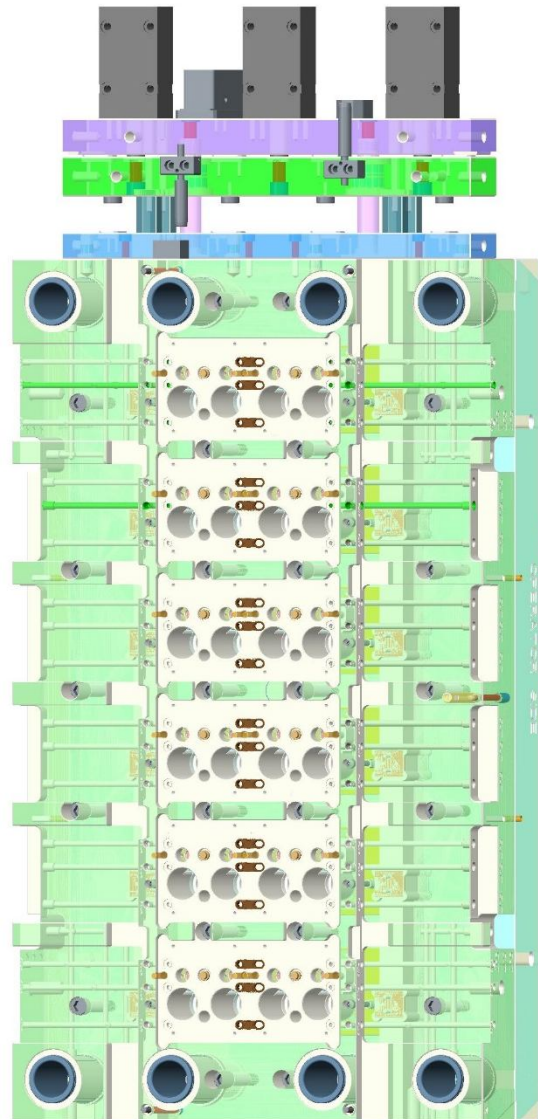
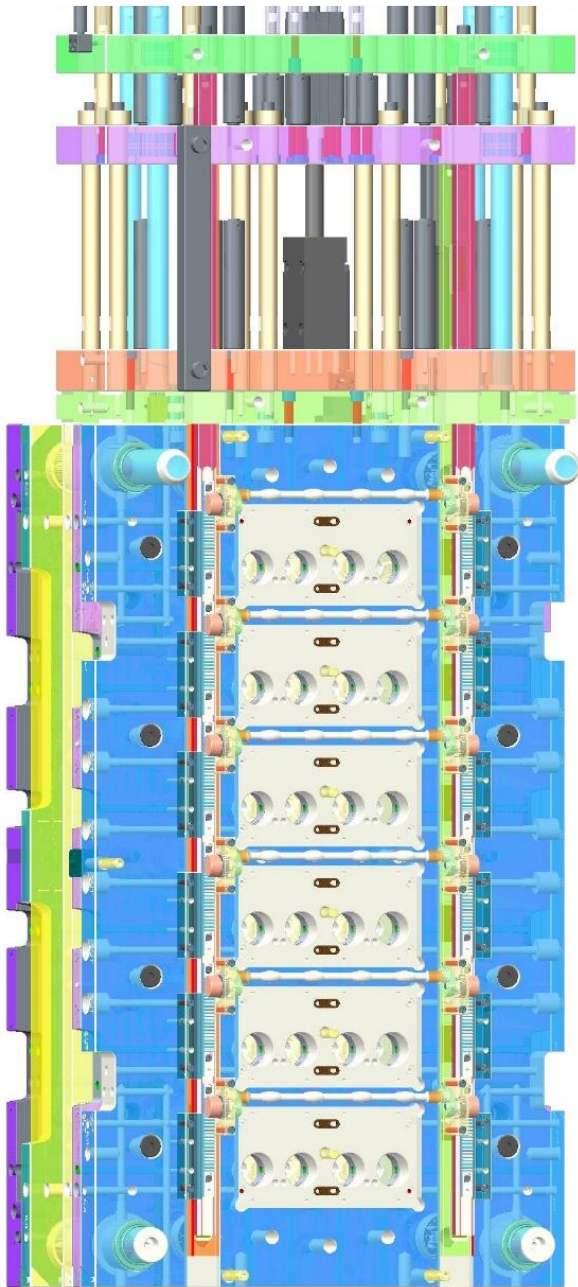

SOME OF OUR MOLD BASE PICTURES.



Parachute Cap Mold Base – 24 cavity

170ml Cap Mold Base – 24 cavity

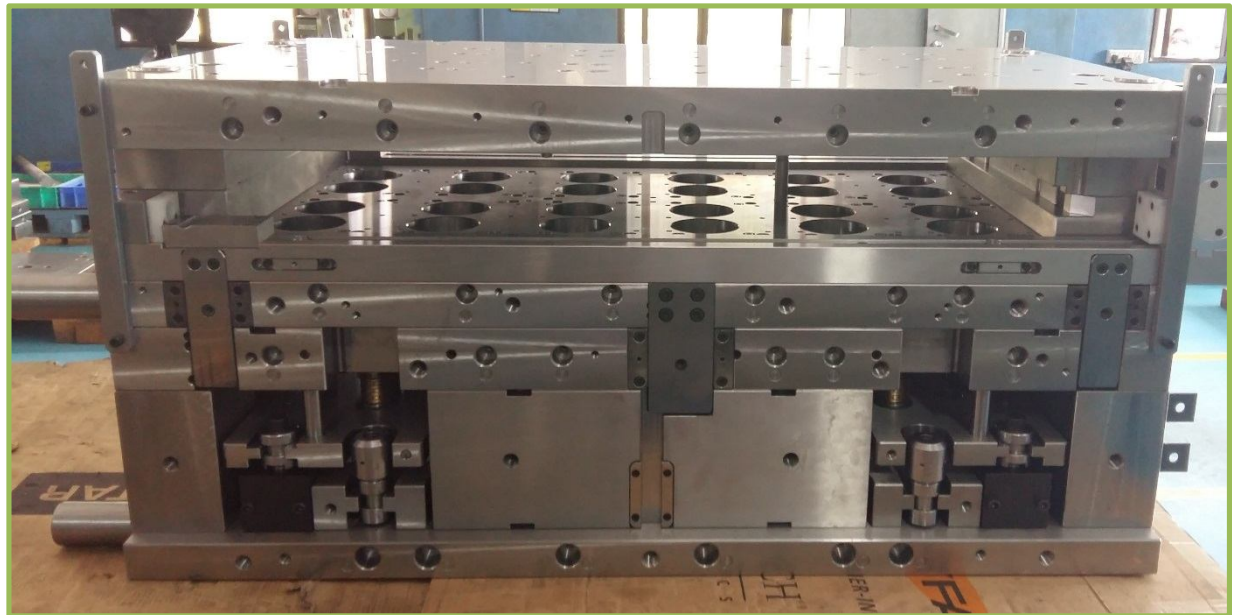

SOME OF OUR MOLD BASE PICTURES.



Harpic Cap Mold Base – 72 cavity

Harpic Plug Mold Base – 48 cavity

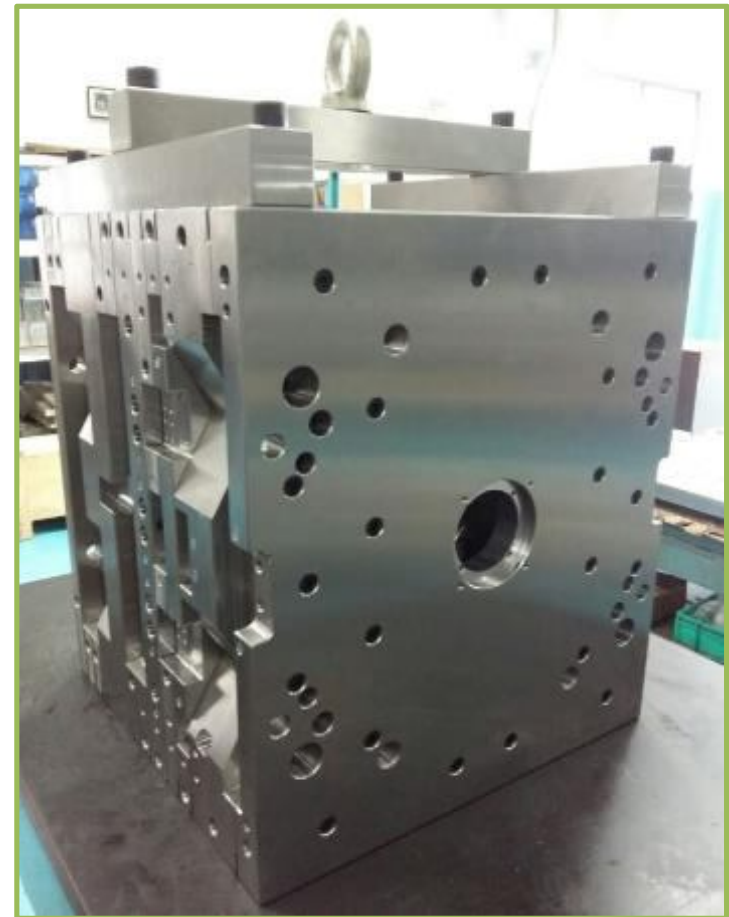

SOME OF OUR MOLD BASE PICTURES.

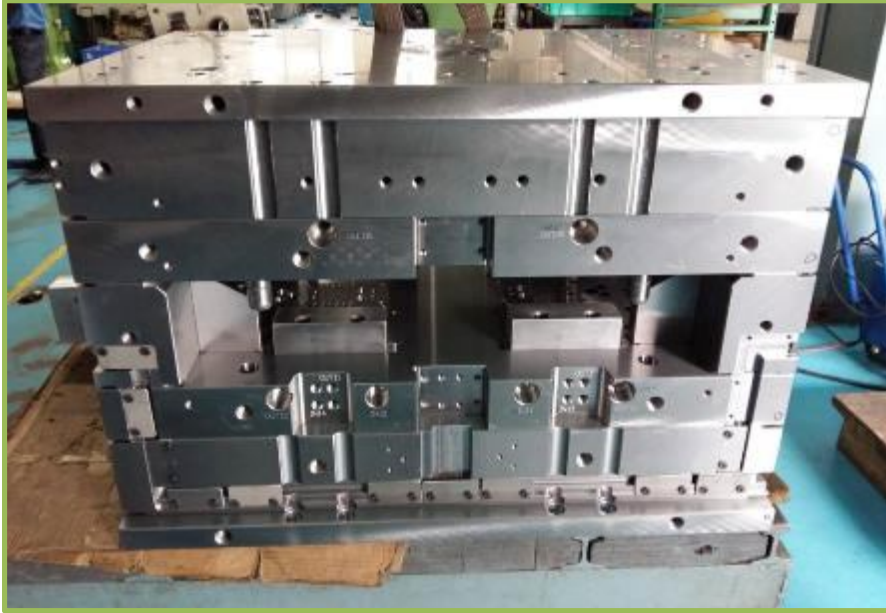

Ezee Handle Mold Base – 8 cavity

Harpic Plug Mold Base – 32 cavity





***THANK YOU
FOR YOUR TIME***